

DAVIE XDc II

User Manual

for Runtime 5.3.0

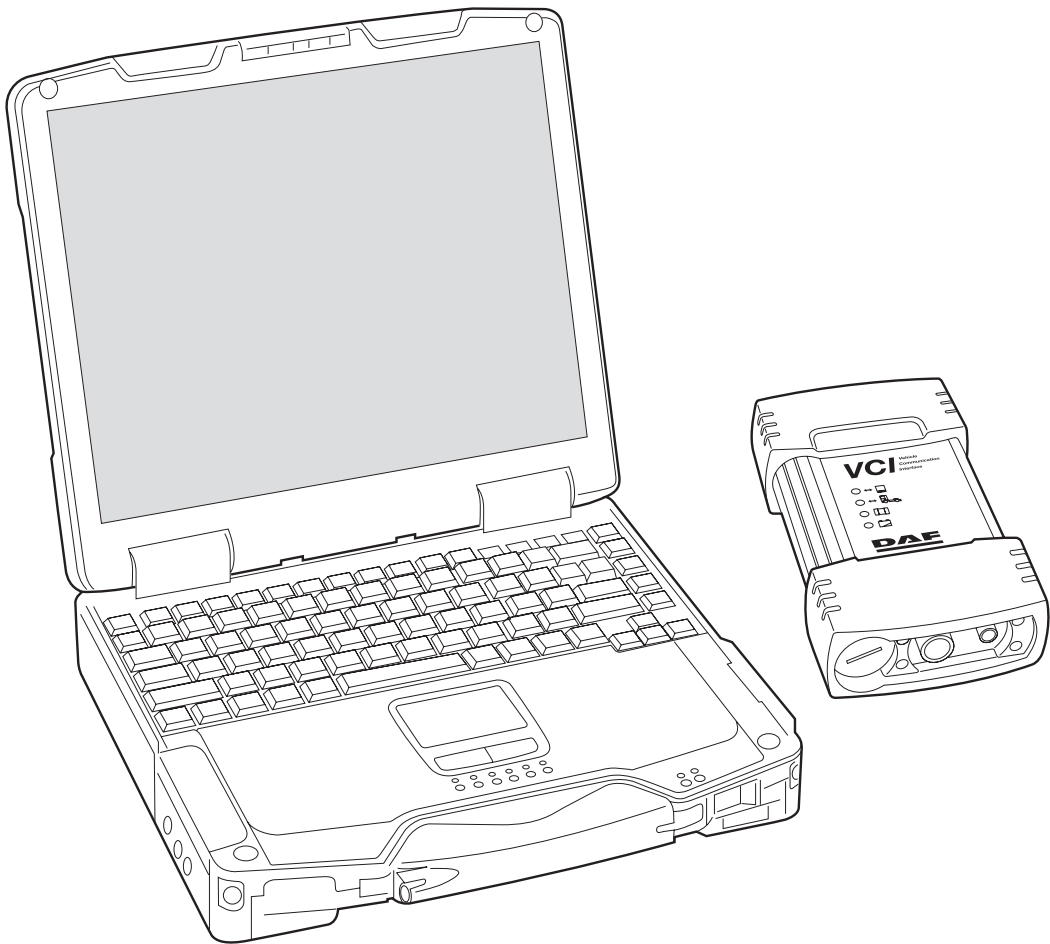

For Laptops with new VCI only

CONTENTS

1	Safety Notices	1-1
1.1	Important safety notices.....	1-2
2	General Information	2-1
2.1	General Notes.....	2-1
2.2	Safety Instructions	2-1
2.3	Designated Use	2-2
2.4	Associated Documents	2-2
2.5	EC Declaration of Conformity	2-3
2.6	Technical Data	2-4
2.6.1	Laptop.....	2-4
2.6.2	Vehicle Communication Interface (VCI).....	2-4
3	Components	3-1
3.1	Overview	3-1
3.2	DAVIE XDc II Laptop	3-1
3.3	DAVIE XDc II Software	3-2
3.4	Vehicle Communication Interface (VCI).....	3-2
3.4.1	Led Status.....	3-4
3.4.2	VCI Battery	3-5
3.4.2.1	Buffering	3-5
3.4.2.2	Charging	3-5
3.4.3	WLAN RF exposure	3-6
4	Operation	4-1
4.1	Power-up	4-1
4.2	Start-up and Exit	4-1
4.3	Administrator Login on a newly delivered or installed DAVIE XDc II	4-1
4.4	User Login	4-8
4.5	Touchscreen (optional)	4-9
4.6	Use of the Screens	4-10
4.7	Logout.....	4-12
4.8	How to switch wired or wireless communication.....	4-13
5	Vehicle Identification	5-1
5.1	Start of Diagnostic Session.....	5-1
5.2	Automatic Identification.....	5-2
5.3	Manual Identification	5-4
5.4	Deselect ECU Installation Variant.....	5-7
6	Direct Testing	6-1
6.1	Overview	6-1
6.2	Vehicle Identification	6-2
6.3	Executing test procedures	6-4
6.4	Navigation bar.....	6-6
6.5	Go To button	6-7
6.5.1	EXIT	6-8
6.5.2	Health Check	6-8
6.5.3	Fault Memory Contents	6-8

6.5.4	Documents	6-9
6.5.5	Test Plan	6-10
6.5.6	ECU Installation Variants	6-11
6.5.7	Direct Test Selection Screen	6-11
6.6	Use of illustrations	6-11
6.6.1	Index page.....	6-12
6.6.2	Explanation of buttons on the screen	6-13
7	Guided Diagnosis	7-1
7.1	Principle op of Guided Diagnosis	7-1
7.2	Starting Guided Diagnosis.....	7-2
7.3	Vehicle Identification	7-2
7.4	Guided Entry	7-3
7.5	Guided entry with Fault code(s)	7-3
7.5.1	Health Check.....	7-4
7.6	Guided entry with a Symptom	7-5
7.7	Test plan.....	7-7
7.7.1	Test plan Overview.....	7-7
7.7.2	Building a Test plan based on Fault codes and Symptoms	7-8
7.7.3	Test plan screen lay out	7-9
7.7.4	Executing tests	7-10
7.7.4.1	Direct test	7-11
7.7.4.2	Symptom test or Check test	7-11
7.7.4.3	Measurement Test	7-12
7.7.5	Function Component selection.....	7-13
7.8	Extra options	7-15
7.8.1	Fault Memory Contents	7-15
7.8.2	Deselecting Systems	7-16
7.8.3	Suspend session	7-17
7.9	Quitting Guided Diagnosis.....	7-21
8	Administration	8-1
8.1	Overview	8-1
8.2	Start Administration	8-1
8.3	Select Function.....	8-3
8.4	Install update	8-4
8.4.1	Install update of a new Runtime CD:.....	8-4
8.4.2	Install update of a new delivered Application CD:	8-4
8.4.3	Install a second language.....	8-6
8.4.4	Install update of a new Parts Rapido Subset CD	8-7
8.4.5	Install update(s) from DAVIE XDc Download.	8-7
8.4.6	Install update from Parts Rapido online	8-8
8.5	Change language	8-8
8.6	Dealership identifier.....	8-9
8.7	Initial Graphic	8-9
8.8	Version information	8-10
8.9	Contents of application data	8-11
8.10	Passwords.....	8-11
8.11	Log Files.....	8-12
8.12	Helpdesk Log Files.....	8-14
8.13	Vehicle test Files	8-14

9	VCI Configuration Manager	9-1
9.1	VCI Tray Icon	9-1
9.2	Start up the VCI Configuration Manager Program	9-3
9.2.1	Status info	9-3
9.2.2	Basic Setup	9-5
9.2.3	Advanced Setup	9-6
9.2.4	Common Settings	9-9
10	Help	10-1
10.1	Overview	10-1
10.2	Start Help	10-1
10.3	Help Overview	10-2
10.4	Help on Topics	10-3
10.5	Help on the selected button	10-4
11	Troubleshooting	11-1
11.1	Classification	11-1
11.2	Computer Hardware	11-2
11.2.1	Laptop self test	11-2
11.2.2	Laptop does not work correctly	11-2
11.2.3	Touchscreen (optional)	11-3
11.3	Software installation	11-3
11.3.1	Windows Explorer popup	11-3
11.3.2	CD incompatible with Base-CD	11-4
11.3.3	Problems with application data	11-4
11.4	Problems with Vehicle Communication Interface (VCI)	11-5
11.4.1	Self-test of the VCI Configuration Manager	11-5
11.4.2	VCI Configuration Manager Self-test error list	11-6
11.4.3	Wireless Communication recovery	11-8
11.5	Fault Report to Local helpdesk	11-9
12	Care and Maintenance	12-1
12.1	Visual check of the DAVIE XDC II components	12-1
12.2	Cleaning the components	12-1
12.2.1	Cleaning the laptop	12-1
12.2.2	Cleaning the VCI	12-1
12.3	Batteries	12-2
12.3.1	Laptop battery	12-2
12.3.2	VCI battery	12-2
12.3.3	Replace the VCI battery	12-2

© 200706 DAF Trucks N.V., Eindhoven,
the Netherlands
In the interest of continuing product
development, DAF reserves the right to
change specification or equipment at any time
without notice.

No part of this publication may be reproduced
and/or published by printing, photocopying,
microfilming or by any other means without
the manufacturer's prior permission in writing.

1 SAFETY NOTICES

Severe injury or damage may result if unqualified persons attempt to work on the equipment or if the safety notices are disregarded.

The safety notices in this operating manual and on the products have the following meanings:



DANGER

Indicates an imminently hazardous situation, which, if not avoided, will result in death or serious injury.



WARNING

Indicates a potentially hazardous situation, which, if not avoided, could result in death or serious injury.



CAUTION

Used with the safety alert symbol, this indicates a potentially hazardous situation, which, if not avoided, may result in minor or moderate injury.

CAUTION

Used without the safety alert symbol, this indicates a potentially hazardous situation, which, if not avoided, may result in property damage.

NOTICE

Used without the safety alert symbol, this indicates a potential situation, which, if not avoided, may result in an undesirable result or state.

NOTE

This is important information about the product or how it is used, or indicates a part of the documentation requiring particular attention.

General safety notices are listed below. Additional safety notices are given throughout the operating manual where they are relevant.

1.1 Important safety notices

Read all the safety notices:



WARNING

Please read the operating and safety instructions which are delivered with the laptop.



WARNING

If the power cable or DAVIE XDc II is damaged, you must not use the DAVIE XDc II until a qualified specialist has tested and, if necessary, repaired the equipment.



WARNING

The power cable must not be laid over tables, benches or cabinets. It must not be located near hot objects or rotating parts.



WARNING

The length of the power cable must not be extended. Use only the supplied power cable as far as possible.



WARNING

The DAVIE XDc II must not be operated in the vicinity of open fuel containers or other open containers with inflammable substances due to the risk of explosion or fire.



WARNING

Make sure there is adequate ventilation when you are working on vehicles with running motors to prevent the risk of carbon monoxide poisoning.



WARNING

Use the DAVIE XDc II only as described in the operating manual. Use only the manufacturer's recommended attachments.



WARNING

The DAVIE XDc II is a safety class 1 device and is equipped with a safety tested power cable. It may only be connected to systems with equipment grounding conductors (TN systems) and grounding sockets.



WARNING

Ensure the DAVIE XDc II is secured during test drives and connect it to the vehicle using the DAVIE XDc II Interface. A second person must operate the DAVIE XDc II.



WARNING

If you open the equipment without authorization or carry out improper repairs, you may place yourself in serious danger.



WARNING

To reduce the risk of electric shock, do not use on wet surfaces or expose to rain.

NOTE

Fluctuations and deviations of the mains voltage beyond the permissible tolerance may lead to electronics failures.

KEEP THESE SAFETY NOTICES IN A SAFE PLACE

2 GENERAL INFORMATION

2.1 General Notes

This operating manual contains the necessary information for the proper use of the "DAF Vehicle Investigation Equipment - Excellence in Diagnosis compact", known as DAVIE XDc II.

Please refer the DAVIE XD user manual for DAVIE XD and or yellow VCI specific issues.

This manual is intended for technically qualified personnel with knowledge in the area of vehicle diagnostics and testing and basic knowledge of Windows XP.

Knowledge and technically flawless implementation of the safety instructions and warnings contained in this operating manual are essential for the safe installation, operation and maintenance of the DAVIE XDc II package.

For reasons of clarity, this operating manual does not contain all the details of all uses of the operating modes described, and cannot cover every conceivable case relating to installation, use, servicing and maintenance. Likewise, the contents of the dialog screens shown here may differ slightly from those displayed on the screen depending on the version.

2.2 Safety Instructions

Pay attention to the safety instructions for the DAVIE XDc II. They are listed after the table of contents.

2.3 Designated Use

DAVIE XDc II may be used for:

- Vehicle diagnosis
- Inform Service Rapido 2.0 and Parts Rapido 2.2

NOTE

DAF has not tested other NON-DAF released applications on the DAVIE XDc II. DAF can not guaranty when other applications have been installed on the DAVIE XDc II, that the DAVIE XDc II application runs free from problems.

The described product was developed, manufactured, tested and documented in accordance with safety standards. Consequently, if the safety instructions, the specified commissioning procedure, the rules governing designated use and the service and maintenance recommendations are followed there is, under normal circumstances, no danger that the DAVIE XDc II will present any risk to property or health and safety.

2.4 Associated Documents

In addition to this operating manual, which is intended for use in the workshop, the following relevant technical documents also apply to the DAVIE XDc II:

- Quickstart Vehicle Communication Interface
- Diagnostic Manual
- Installation Manual
- Application Information

2.5 EC Declaration of Conformity

EG- Konformitätserklärung
EC – Declaration of Conformity

Wir / We,
Softing AG
Richard-Reitzner-Allee 6
D-85540 Haar (Germany)

erklären hiermit, dass das Produkt / declare that the product

Typ / type:
Vehicle Communication Interface

Modell / model:
VCI-560

mit den Anforderungen der europäischen EMV-Richtlinie 89/336/EWG, der R&TTE Richtlinie 99/5/EG und mit den Änderungen der Richtlinie 93/68/EWG übereinstimmen.

complies with the requirements of the European EMC directive 89/336/EEC, the R&TTE directive 99/5/EC and with the amendments of directive 93/68/EEC.

Angewandte harmonisierte Normen / Harmonised standards applied:

- EN 55022:1998 + Corrigendum July 2003 + A1:2000 + Corrigendum April 2003 + A2:2003 class A
- EN 55011:1998 + A1:1999 + A2:2002 + A1:1999+ A2:2002 group 1/class A
- EN 61000-6-4:2001
- EN 61000-6-2:2005
- ETSI EN 300328-2 V1.6.1 (2004-11)
- ETSI EN 301489-17 V1.2.1 (2002-08)
- EN60950-1:2006

Haar, 18.05.2007

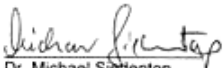
Dr. Michael Siebertop
Vorstand / member of board

DAVIE XDc II

General Information

2.6 Technical Data

2.6.1 Laptop

See originally delivered documentation which is delivered with the laptop.

2.6.2 Vehicle Communication Interface (VCI)

Dimensions (W x D x H)	126 x 214 x47 mm
Weight	1.1 kg
Ambient conditions	
Operation	Ambient temperature 0 to +50 °C Relative humidity 10 to 90 %, non-condensing at max. +25 °C
Storage	Ambient temperature -20 to +80 °C Relative humidity <90% non-condensing)
Temperature gradient	5 °C/1 h
Power supply from the vehicle electrical system	The VCI must be powered from the vehicle.
Rated voltages	8 to 32 V DC
Current consumption in the load range	Max. 1 A
Power supply from the rechargeable battery	If external power is interrupted, the VCI will be buffered by the rechargeable battery
Battery type	NiMH 4,8V/1100mAh
Buffered time	Between 20 and 60 sec or no buffering
Communication	
USB	For communication by wire to the DAVIE XDc II
Wireless LAN	For wireless communication to the DAVIE XDc II via a (internal) wireless network card according 802.11b and 802.11g

WLAN module VCI

Used WLAN-Module:	WiPort from Lantronix Inc.
Frequency Range:	802.11b/g = 2400 – 2483.5 MHz
Type of Transmission:	Direct Sequence Spread Spectrum
Transfer Rate:	1/5.5/11 Mbps for 802.11b mode 6/36/54 Mbps for 802.11g mode
Number of Channels:	802.11b mode (2400-2483.5 MHz) = 11 802.11g mode (2400-2483.5 MHz) = 11
Modulation Type:	CCK, OFDM
Transmit Output Power:	Ch. 1-11 14dBm Average (Typical) for 802.11b mode Ch. 1-10: 14dBm Average & Ch. 11: 12dBm Average(Typical) for 802.11g mode

DAVIE XDc II
General Information

3 COMPONENTS

3.1 Overview

DAVIE XDc II system features;

- Portable equipment DAVIE XDc II Laptop with an optional touchscreen and installed with the DAVIE XDc II software packages: Runtime, Application and Parts Rapido Subset.
- USB or wireless communication with the diagnostics interface in the vehicle via the DAVIE XDc II Vehicle Communication Interface (VCI).
- VCI Configuration Manager program to set-up the wireless communication between the DAVIE XDc II and the DAVIE XDc II Vehicle Communication Interface (VCI).

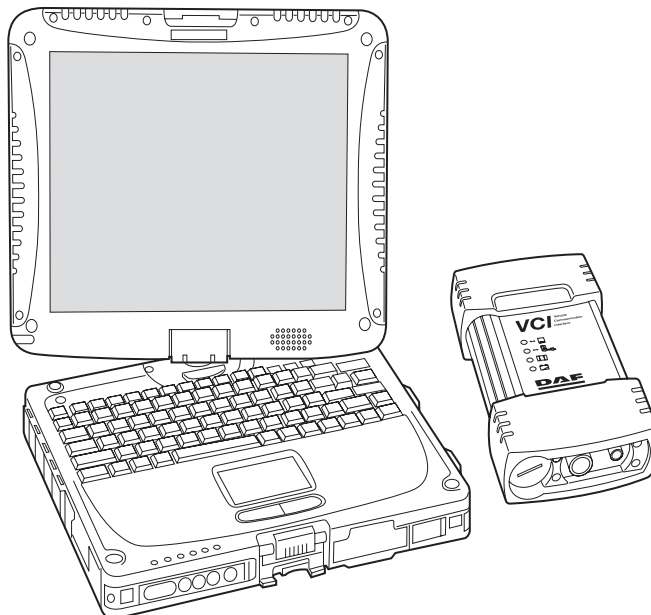

Figure 3-1 DAVIE XDc II Panasonic CF-19 with VCI

3.2 DAVIE XDc II Laptop

See originally documentation which is delivered with the laptop.

3.3 DAVIE XDc II Software

For optimal functioning of the DAVIE XDc II, three CD's must be installed. The Runtime, Application and Parts Rapido Subset are needed to operate with the DAVIE XDc II. These CD's are already installed at delivery.

Description of the CD's

CD	Content	Update sequence
Runtime	Diagnostic Operation system	~ once a year
Application	System tests for Direct Test and Guided Diagnosis	Normally every 8 weeks
Parts Rapido Subset	Truck database	Every 4 weeks

3.4 Vehicle Communication Interface (VCI)

The DAVIE XDc II communicates with the ECU's installed in the truck via the truckside "Diagnostic Connector" by using a special communication interface, called the Vehicle Communication Interface (VCI).

The VCI switches the input channel automatically to the required data line (K-line, L-line) or CAN-bus of the truckside "Diagnostic Connector".

The DAVIE XDc II provides two options for the communication between VCI and DAVIE XDc II, wireless or via cable (USB). Normally, the VCI communicates with the DAVIE XDc II by Wireless-LAN radio communication.

NOTE

Please take care. The use of wireless communication has to conform to the local regulations of your country.

The VCI is equipped with a battery to prevent immediate shut down of the VCI when the power supply is interrupted for a short time. (e.g. ignition off)



Figure 3-2 VCI Complete view

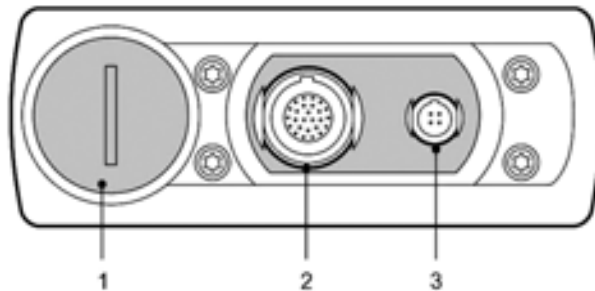

Figure 3-3 VCI View of the top side of the housing

1. Battery plug
2. Vehicle Diagnostic Cable Connector
3. USB-Connector

NOTE

Wireless communication is not possible when the USB cable is connected to the VCI.

3.4.1 Led Status

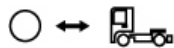

Figure 3-4 VCI Front view LED



Yellow LED: DAVIE XDc Communication

On:	Communication
Slow flashing:	WLAN-Mode changing Adhoc <--> Infrastructure
Off	No communication



Blue LED: Vehicle communication

On:	Communication
Off:	No vehicle communication

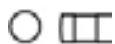

Green LED: VCI Internal status

On:	Firmware is running
Slow flashing:	Update
Fast flashing:	Over temperature
Off	VCI off or internal error



Red LED: Battery status

On:	Battery malfunction
Slow flashing:	Not ready for buffering and last 10 seconds of buffering
Fast flashing:	Over temperature, no charging possible
Off:	No battery or battery ready

NOTE

Temperature monitoring is implemented in the VCI. This protects the VCI against damage from overheating.

When a critical temperature is reached, the user is warned by a fast flashing red LED. If the user does not react and the temperature rises over the limit value, the VCI is switched off.

The VCI has to cool down for approximately 10 minutes before it can be reactivated.

3.4.2 VCI Battery

3.4.2.1 Buffering

To prevent immediate shutdown of the VCI during periods in which the vehicle's power supply is switched off (e.g. in order to reset electronic control units in the vehicle), the VCI is capable of buffering itself for a brief period between 20 and 60 seconds.

The last 10 seconds of buffering are indicated by slow flashing of the red LED. With the VCI Configuration Manager the buffer settings can be changed between 20 and 60 seconds or turned off.

3.4.2.2 Charging

The battery will be charged each time the VCI is connected to the vehicle and the vehicle's power supply. After power-up, the battery is charged for 5 minutes with a high current. After this time period, charging switches to a mode with low current.

The battery indicator flashes if the buffer function is not possible. The VCI shuts down immediately whenever the power supply is disconnected.

In case of long storage periods a deep discharge of the battery is possible. In this case a minimum charging time of 20 minutes is necessary to bring up the batteries to their normal use range and to permit the VCI buffering for one cycle.

Overcharge of the batteries will be avoided.

NOTE

Over temperature protection of the batteries is monitored by a temperature sensor.

3.4.3 WLAN RF exposure

This device complies with the FCC RF (radio frequency) Exposure Requirements set forth for an uncontrolled/general population environment. A separation distance of 20 cm between the transmitting antenna and the human body must be assured during normal operating conditions.

The Part 15 radio device operates on a non-interference basis with other devices operation at this frequency when integrated antennas. Any changes or modification to the product not expressly approved by the manufacturer could void the user's authority to operate this device.

This device complies with part 15 of the FCC Rules. Operation is subject to the following two conditions:

1. This device may not cause harmful interference, and
2. this device must accept any interference received, including interference that may cause undesired operation.

4 OPERATION

4.1 Power-up

See, for start-up of the DAVIE XDc II laptop, the originally delivered laptop documentation.

4.2 Start-up and Exit

To start the DAVIE XDc II software, double click on the DAVIE XDc II Icon on the desktop or by the shortcut in the Windows Start menu.



Figure 4-1 DAVIE XDc II Icon

To close the DAVIE XDc II software, use the cross in the upper right corner.

4.3 Administrator Login on a newly delivered or installed DAVIE XDc II

At the first start up after installation of DAVIE XDc II Runtime CD, you must enter your dealership code to access the DAVIE XDc II operating modes. Later changes or deletions of an entered dealership code cannot be made in the workshop.

When the DAVIE XDc II is started for the first time the Login button at the right hand margin of the screen and the version information of the Runtime, Application and Parts Rapido Subset is displayed in the upper parts of the screen.

NOTE

The Application and parts Rapido Subset version information is not displayed after a complete new Runtime installation.
First install the latest Application and Parts Rapido Subset version when you enter the administrator menu.

DAVIE XDc II

Operation



Figure 4-2 Start screen before Login

To start up the DAVIE XDc II, the **DAVIE XDc II Administrator** must proceed as follows:

1. Press the "Login" button (see Figure 4-2).
2. The screen in Figure 4-3 is displayed. Under "User ID", enter "ADMIN" and press the "Return button" on the keyboard.
3. Under "Password", enter password "DAF". Press the "Return button" on the keyboard.

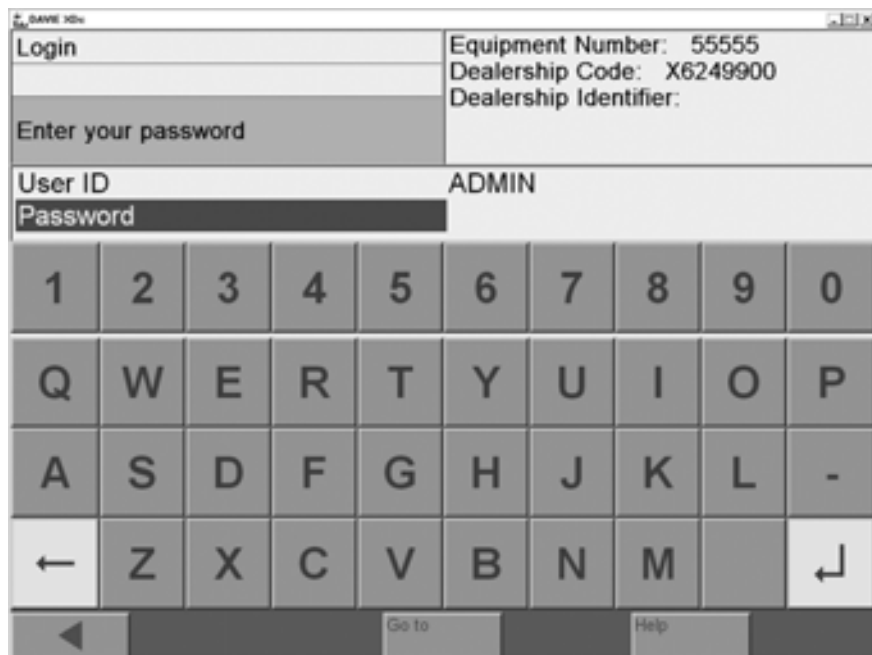

Figure 4-3 "Login" screen: entering the password

4. Then enter an Administrator password of your choice.
5. After entering the password, press the "Return button" again. A display is prompted to insert the dealership code USB-stick containing the personal dealership code for this DAVIE XDc II laptop. Press "OK" to continue.



Figure 4-4 "Insert dealership code"

6. DAVIE XDc II will terminate the function and return to the start screen.

The label of the "Login" button has changed to "Logout" and a new button "Administration" is displayed.

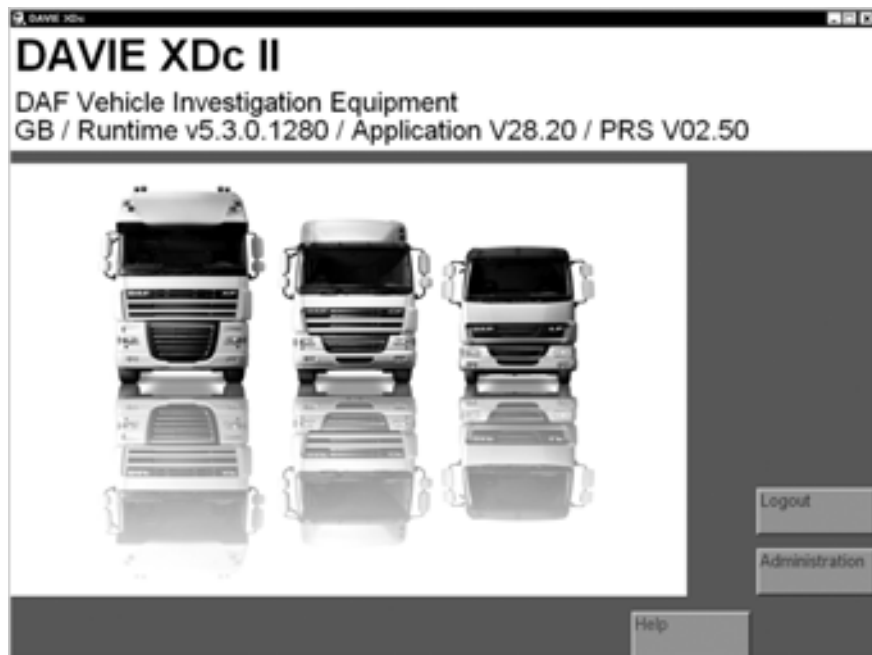

Figure 4-5 Start screen after 1st login

7. In the start screen, press the "Administration" button to access the administration menu.
8. Select "Passwords" (see Figure 4-6).

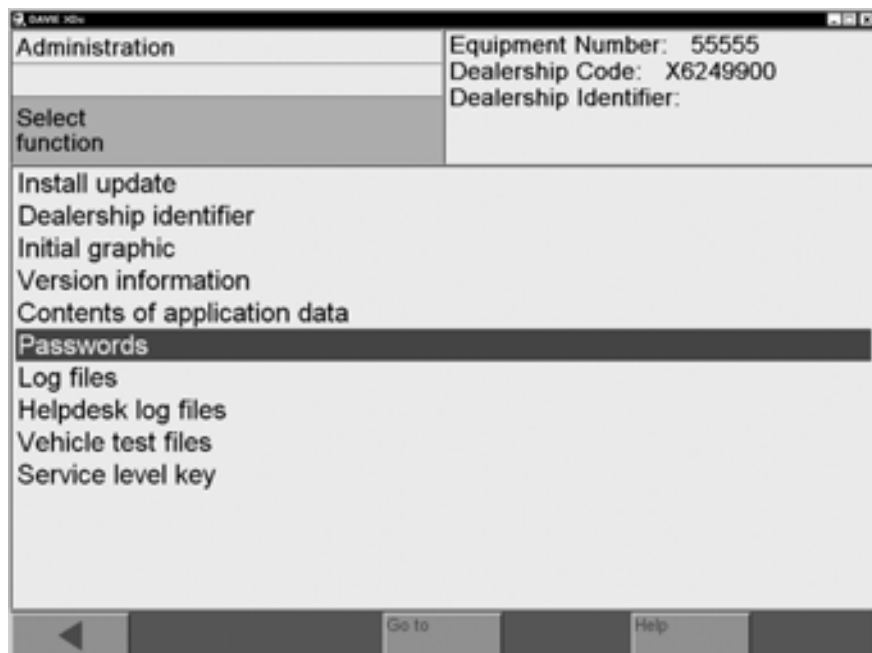

Figure 4-6 Administration screen: select function "Passwords"

9. In the "Passwords" screen, users of the DAVIE XDc II system and passwords can be add and changed (see Figure 4-7). All entered users are displayed with their user levels and hidden passwords.
 - To edit an entry, select the relevant element in the "User ID" column. A dialog box opens in which you can edit the user level of the selected user.
 - To add an additional user, select an empty element in the "User ID" column.
 - To enter or change passwords, select the corresponding element in the "Password" column.

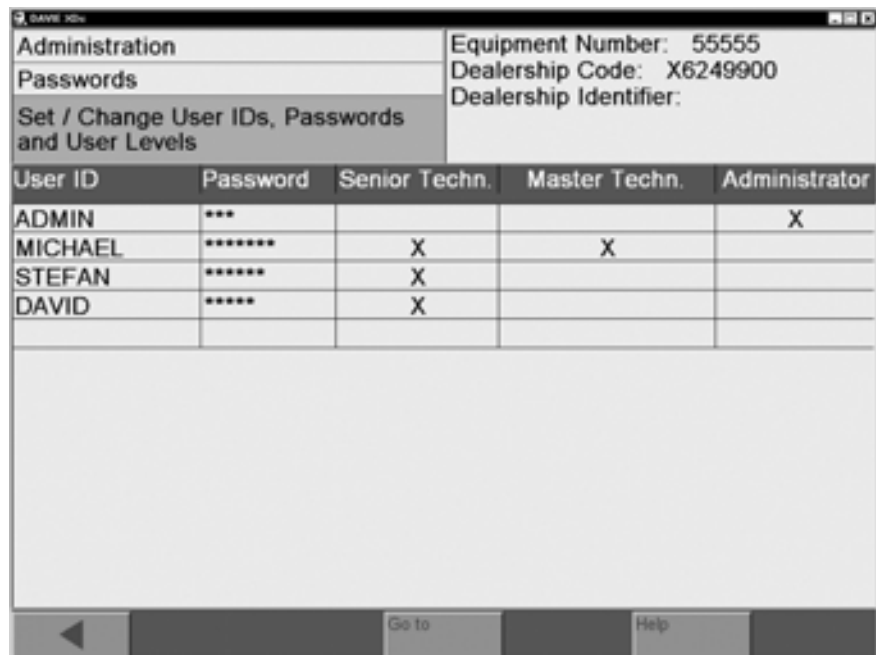

Figure 4-7 Administration screen: user set-up

NOTE

Depending on the different user levels "Senior Technician" and "Master Technician" only those test procedures to which the specific technician level has access to will be displayed by the DAVIE XDc II and implemented by the technician.

The Senior Technician can only readout in- and outputs and diagnose. The Master Technician has also the rights to program the ECU's.

Only the Administrator has rights to add users and to set the Passwords. If a column is selected, a virtual keyboard appears and a new user can be typed in or a selected one can be changed.



Figure 4-8 Keyboard

10. Enter the User Level of "Senior Technician" or "Master Technician" and usernames including the passwords.
11. When all required users are entered, exit the function by pressing the "Back / <" button to return to the "Administration" screen.
12. In the "Administration" screen, select "Dealership Identifier".

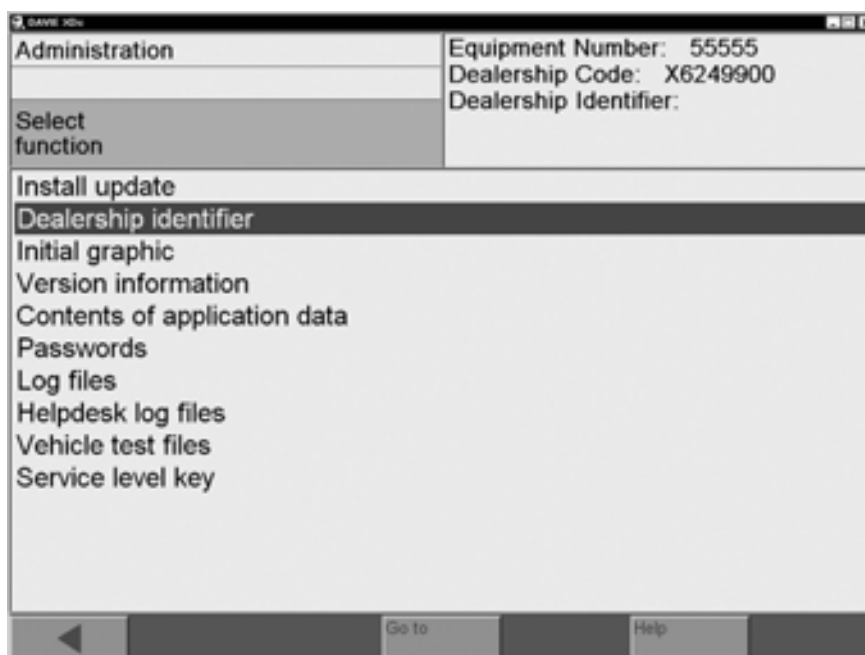

Figure 4-9 Administration screen, select function "Dealership Identifier"

13. If selected the function, a keyboard will be displayed and type in a new "Dealership Identifier" or change it.

Use the "SH" button of the keyboard to switch between upper and lower case letters.

Press the "Back / <" button to return to the "Administration" screen.

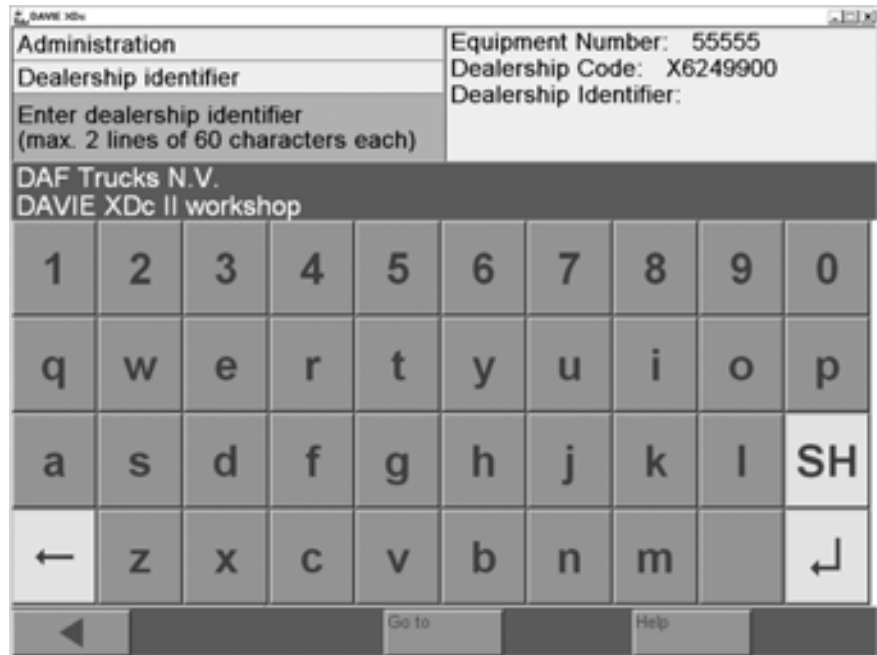

Figure 4-10 Keyboard: Dealership Identifier

14. The final basic setting, which could be implemented before starting to work with the DAVIE XDc II, is to change the "Initial graphic", the displayed graphic in the start screen.

Use the "Forward / >" button to go step by step through all available "Initial Graphics".

Use the "Back / <" button to accept the displayed graphic in the start screen and to return to the "Administration" screen.

15. Return to the start screen and logout as Administrator.

16. It may be necessary to set a unique VCI-ID if more than 1 pair of DAVIE XDc II and VCI is used in the same workshop (refer to "Configuration manager").

4.4 User Login

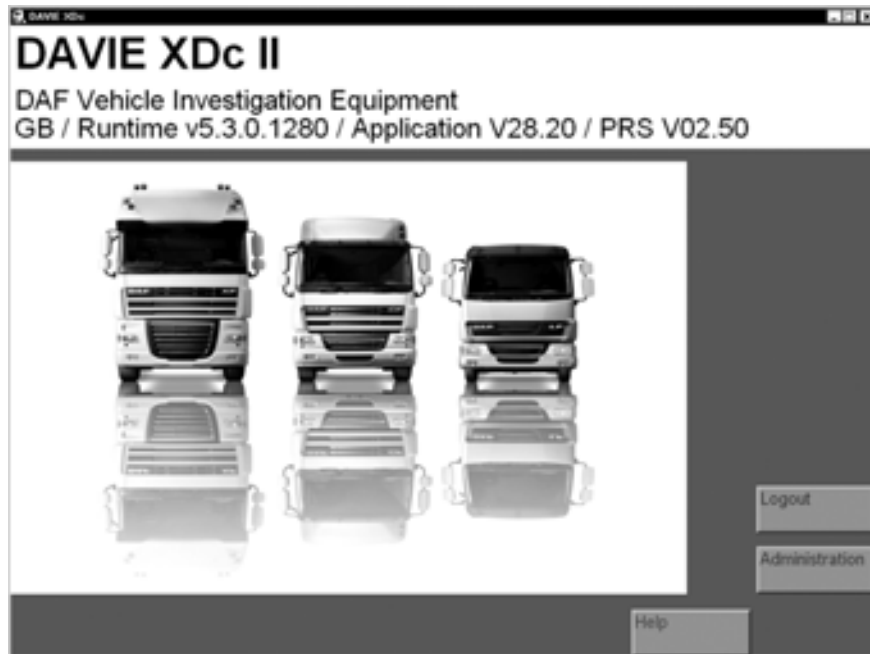

Figure 4-11 Start screen: Administrator Login

The DAVIE XDc II is ready for use when the system start screen is displayed.

The "Help" function can be selected in all modes and provides information on operation and on the functions of the individual navigation buttons.

To access the buttons for the functions "Direct Test" and "Guided Diagnosis", the user must login with their "User name" and personal "Password". To do this, press the "Login" button and enter the required personal data.

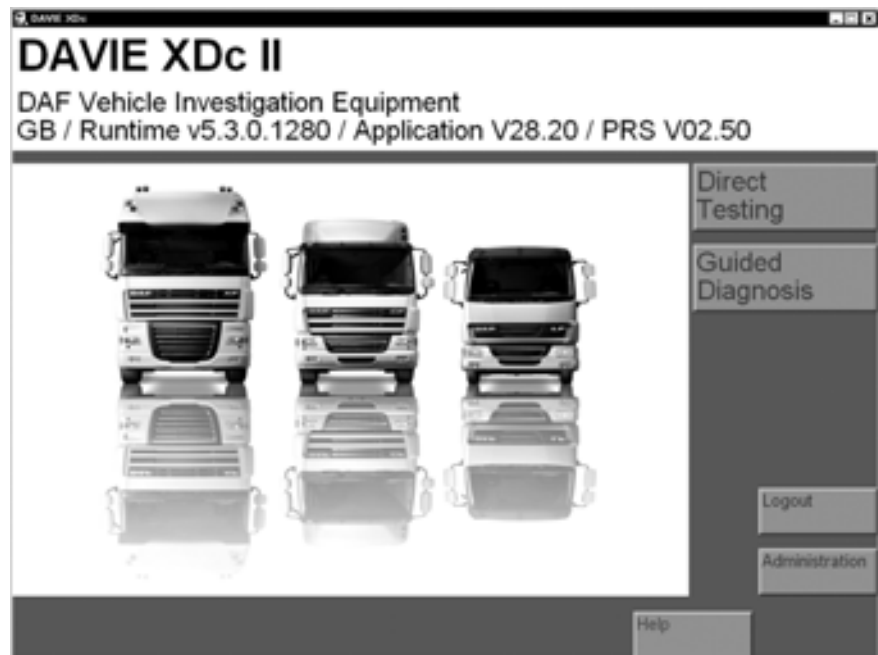

Figure 4-12 Start screen: User Login

4.5 Touchscreen (optional)

The entire touch-sensitive surface of the screen is designated as the touchscreen.

The screen senses touch by a finger or delivered touch pen, thereby replacing the conventional function of a mouse or keyboard. To select an element (text or button), you must touch it on the screen.

As long as you are touching the screen, you can change the current selection. When you stop touching the screen, the selected element is activated.

See for more features and settings of the touchscreen also the original documentation which is delivered with the laptop.

NOTE

The screen reacts to all touch. When using the DAVIE XDc II, make sure it can not be touched unintentionally by any equipment or people.

Do not use any other objects than your finger or delivered touch pen to operate the screen. Using other objects can result in damage.

4.6 Use of the Screens

The graphical screens display all information and control functions.

The screens shown all the same structure: the lower portion contains a bar with operating elements (the navigation bar), the middle and largest portion contains the work window in which you make your selection or enter values. The information windows are above the work window.

NOTE

If the DAVIE XDc II is not used for a time, the screensaver could be activated. This is a Windows XP setting. As soon as you press the screen **near the upper left edge** (so as not to unintentionally launch any screen functions), the screen activated last is displayed.

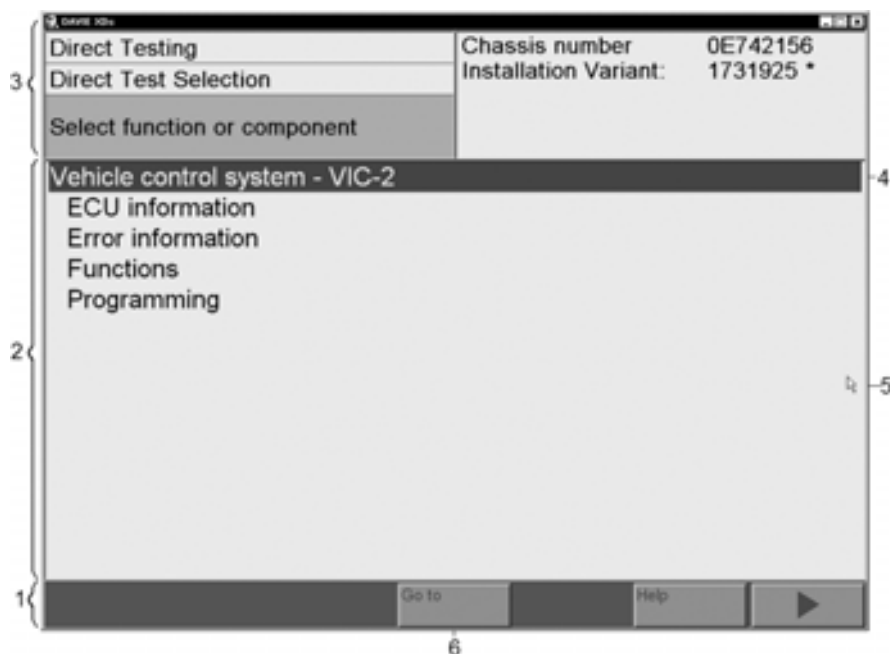

Figure 4-13 Overview: Screens

1. Navigation bar
2. Work window
3. Information windows
4. Selection bar
5. Pointer
6. Button on the navigation bar

Navigation bar (1)

The navigation bar is in the lower portion of the screen. You can call up help and service functions with the buttons in this bar.

There are up to five different buttons available on the navigation bar. The number of buttons depends on the screen and the current status. Press the button to execute the desired command. You can recognize whether a button is active by its colour. If the button is darkened, it has been pressed and activated.

Button "Go to"

The navigation bar includes the "Go to" button, with which you can:

- Exit the diagnostic session
- Jump across several different screens to a specified destination screen

Work window (2)

The work window is the largest portion of the screen. The display changes depending on the operating mode.

Information window (3)

Most screens contain two information windows above the work window. These windows are only for displaying information; they do not control any operations.

- The left window displays the name of the operating mode: Direct Testing), the name of the displayed subfunction (here: Function/ Component Selection) user instructions (here: Select function or component) or status display.
- The right window displays the device number and workshop identifier, terms that you have previously selected or selected function.

Selection bar (4)

When you select a line within the work window, your selection is highlighted by a black selection bar. The text portion you select is inverted. It is possible to scroll between the displayed lines while constantly pressing the screen or mouse button. If the list is larger than the screen, a scroll bar will appear on the right-hand side.

In most cases, the next screen is activated as soon as you stop pressing the screen or mouse button after you have marked a text.

In some screens, there is only a single selection of lines possible so, if you select one line, a previously selected line will be automatically deselected. Otherwise, the DAVIE XDc II offers you the option of selecting or deselecting multiple options. Select or deselect all the options you want and confirm it by pressing the "Forward / >" button.

Pointer (5)

The pointer takes on various shapes depending on its current function.

- With the arrow you can select functions or buttons.
- The hourglass appears when the DAVI XDc Laptop is processing your entries.

While the hourglass is displayed, you cannot make any entries. Wait until the pointer returns to the form of an arrow.

Buttons (6)

Each screen contains different buttons. You can select various functions with these buttons.

You can recognize whether a button is active by its colour. If the button is darkened, it has been pressed and activated buttons are displayed on the navigation bar. The number of buttons depends on the screen and the current status.

4.7 Logout

To logout an Administrator or User, press the "Logout" button in the start screen, then only the "Login" and "Help" buttons are displayed. Another user may now log in.

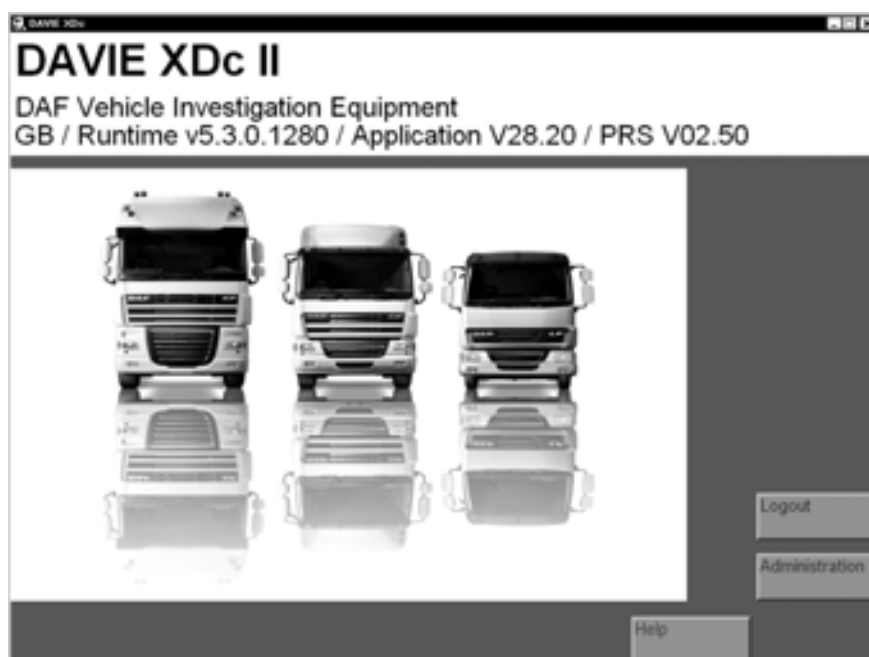

Figure 4-14 Standard screen before "Logout"



Figure 4-15 Standard screen after "Logout"

4.8 How to switch wired or wireless communication

The DAVIE XDc II provides two options for the communication between VCI and DAVIE XDc II, radio and USB communication. Normally the VCI communicates with the DAVIE XDc II by Wireless-LAN radio communication.

The safest way to change the communication is to close the DAVIE XDc II program and connect or disconnect the USB-cable.

5 VEHICLE IDENTIFICATION

The DAVIE XDc II has two options for identifying a vehicle and the used systems.

- Automatic vehicle identification
- Manual vehicle identification

The automatic vehicle identification from the truck chassis number and the "Parts Rapido Subset" database is usually used. This ensures that the assignment of the test procedures corresponds to the vehicle configuration.

If automatic identification from the truck chassis number is not possible, manual identification can be carried out.

NOTE

The complete vehicle configuration is saved in the log file.

5.1 Start of Diagnostic Session

If a diagnostic Session is started (Direct Test or Guided Diagnosis), DAVIE XDc II checks the communication to the Vehicle Communication Interface. After the communication check, the vehicle identification will be started.

When the communication is unsuccessful the DAVIE XDc II displays a message.

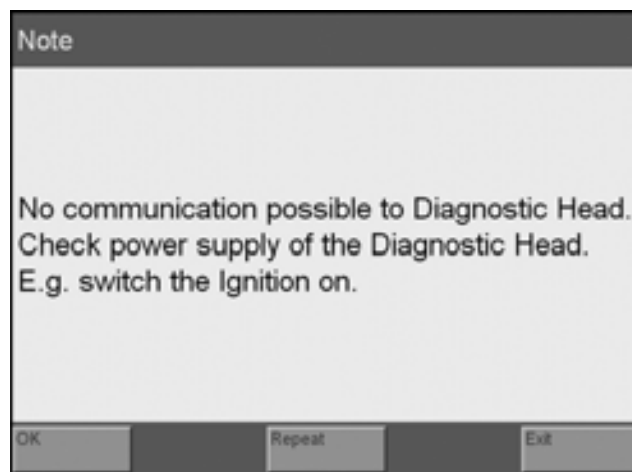

Figure 5-1 Communication verification message

- **OK**

This option instructs DAVIE XDc II to ignore the inability to establish communication and display the Vehicle Identification screen.

DAVIE XDc II now displays the Vehicle Identification screen and waits for the user to enter the "Chassis" number. There is still no communication between the DAVIE XDc II and VCI.

- **Repeat**

This option instructs DAVIE XDc II to repeat the attempt to establish communications. If successful, the system will display the Vehicle Identification screen.

- **Exit**

This option instructs DAVIE XDc II to cancel "Diagnostic Session" and to return to the "Start Screen".

All options other than "OK", Repeat" and "Exit" are locked and unavailable to the user.

5.2 Automatic Identification

Automatic vehicle identification can be done by the DAVIE XDc II if the truck is equipped with an ECU which stores the necessary data.

Another way of automatic vehicle identification is to enter the "chassis number" when a chassis number can't automatically be found in the ECU which stores the necessary data. The entered chassis number is compared with the entries in the "Parts Rapido Subset" database.

If the chassis number is found, the related installation variant numbers of the system are accessed and only the corresponding variants are used for Direct Test and Guided Diagnosis.

The complete automatic vehicle identification runs on the background. When the automatic vehicle identification is complete the Direct Test or Guided Diagnosis entry screen is displayed.

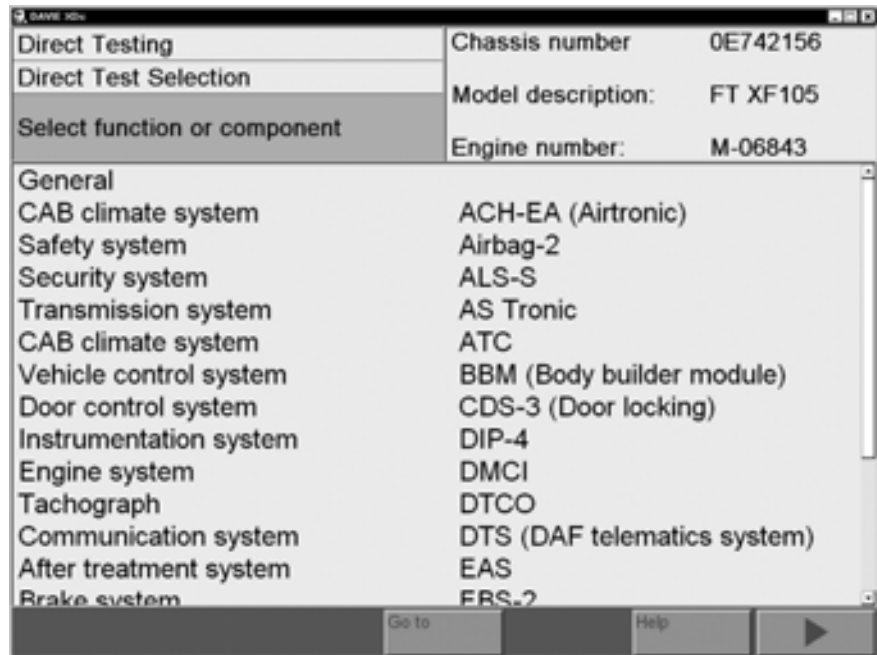

Figure 5-2 Automatic identification by "Parts Rapido Subset" database

5.3 Manual Identification

If the chassis number could not be found in the Parts Rapido Subset database, the following message box will appear. It is possible to switch to manual selection by selecting the "Manual" button or to return to the start screen by selecting the "Exit" button. If pressed "Exit" then, update the Parts Rapido Subset data by an update from Parts Rapido online and then try the automatic identification again.

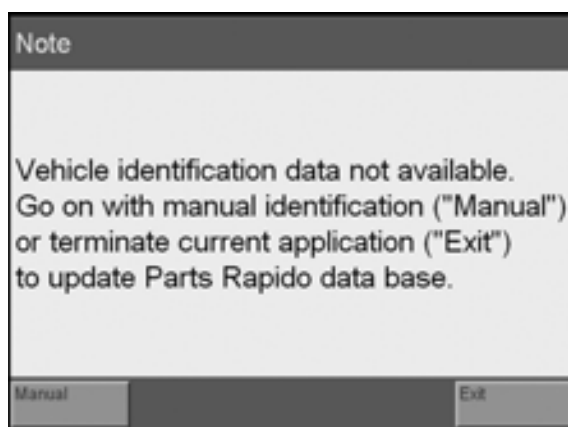

Figure 5-3 Note: Manual identification

NOTE

This message box will also appear when the Parts Rapido Subset is not installed.

If the "Manual" button is selected, all possible systems will be displayed, even systems that are not mounted on the vehicle. To select the required variants, carry out the following steps:

1. Select a system by pressing the name of the system. The installation variants of the system are displayed automatically on the screen.

The system name is marked with a bar.

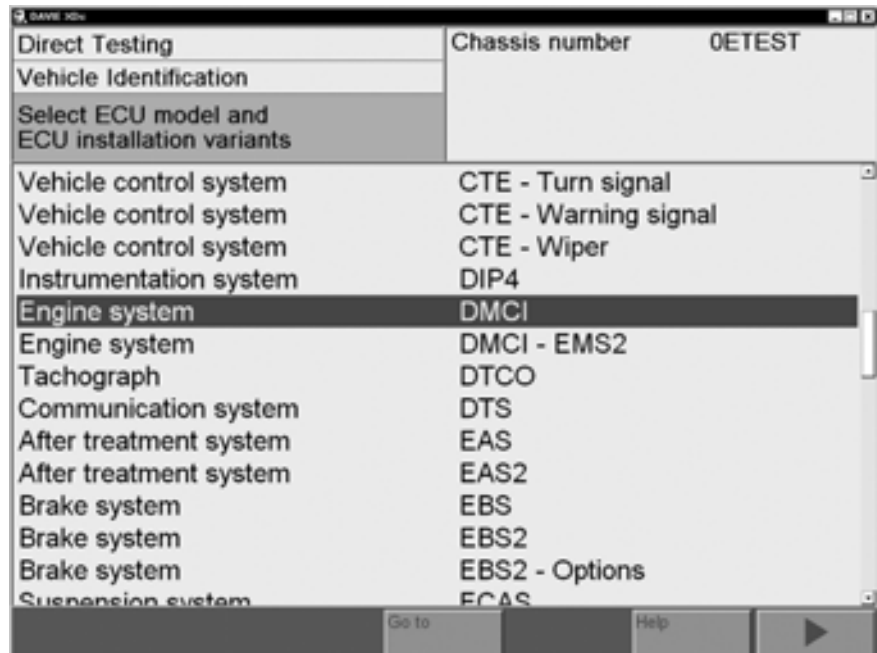

Figure 5-4 Manual system selection

2. Select one of the listed variants based on the DAF Mainframe or Parts Rapido online, Helpdesk or other similar information.

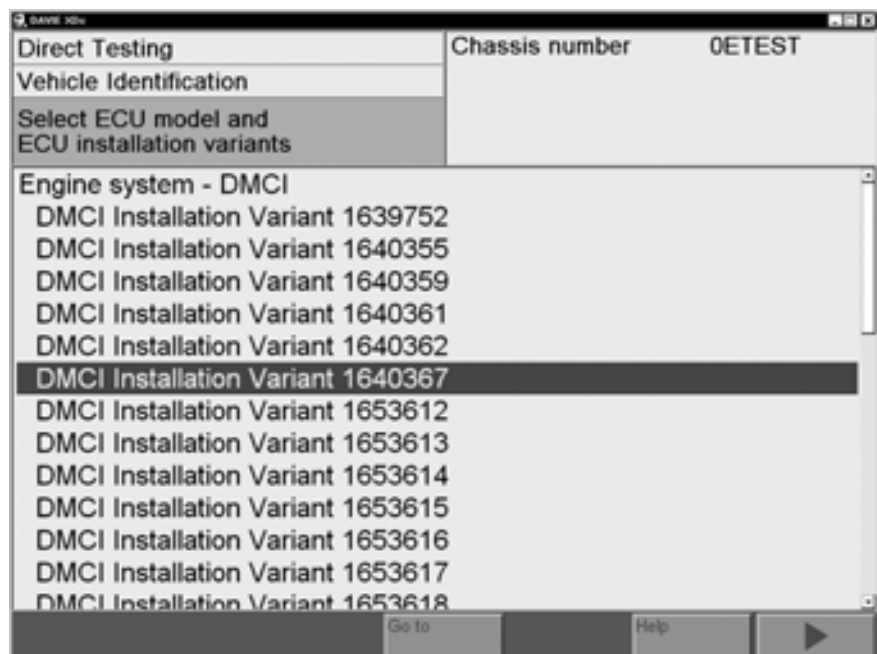

Figure 5-5 Manual system variant selection

The selection is marked with a bar. Confirm the selection with the "Forward / >" button. The Direct Test or Guided Diagnosis screen is displayed.

By selecting the system name, it is possible to switch back to the system selection list.

DAVIE XDc II

Vehicle Identification

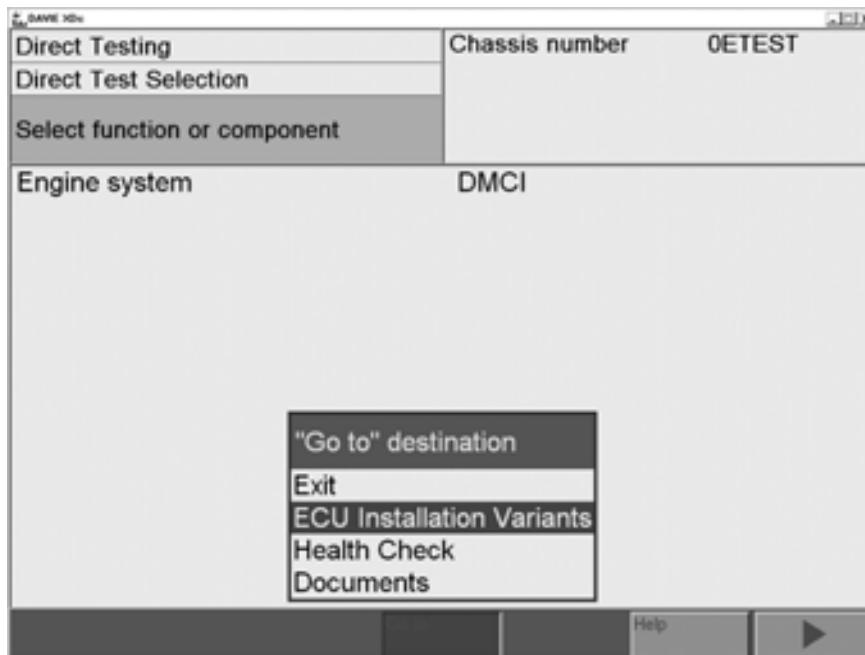

Figure 5-6 System selection, Go to "Installation variants"

3. If more systems need to be selected, use the "Go to" button and select "ECU Installation Variants". The already chosen system installation variants are displayed.

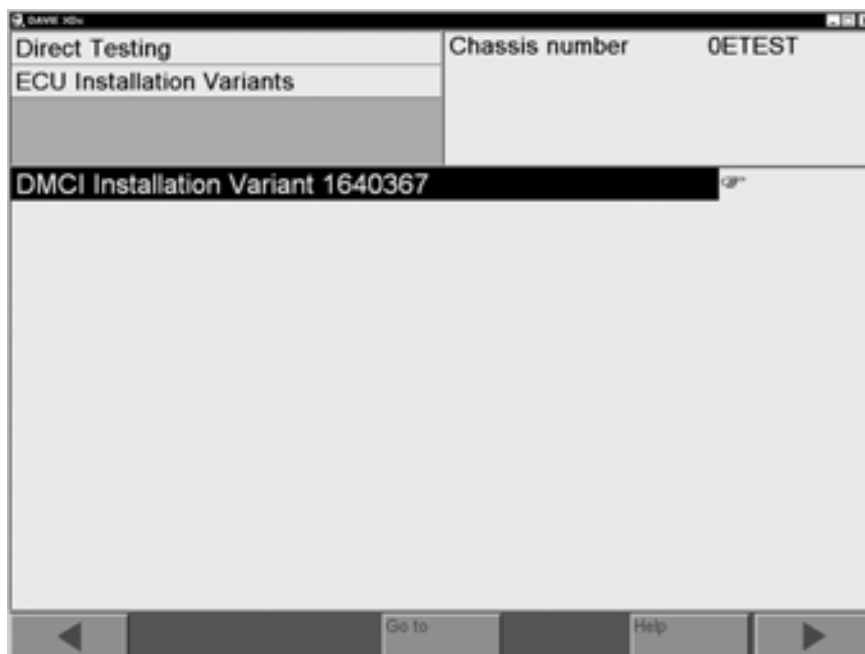

Figure 5-7 Overview: manual selection

4. Press the "Back / <" button to switch to the system selection screen and select a system. Like step 1, figure 5-4.

Repeat steps 1 to 4 to select more systems.

5.4 Deselect ECU Installation Variant

After the automatic or manual variant selection is finished, DAVIE XDc II displays the Direct Test or Guided Diagnosis screen.

If a system needs to be deselected, use the "Go to" button and select "ECU Installation Variants".

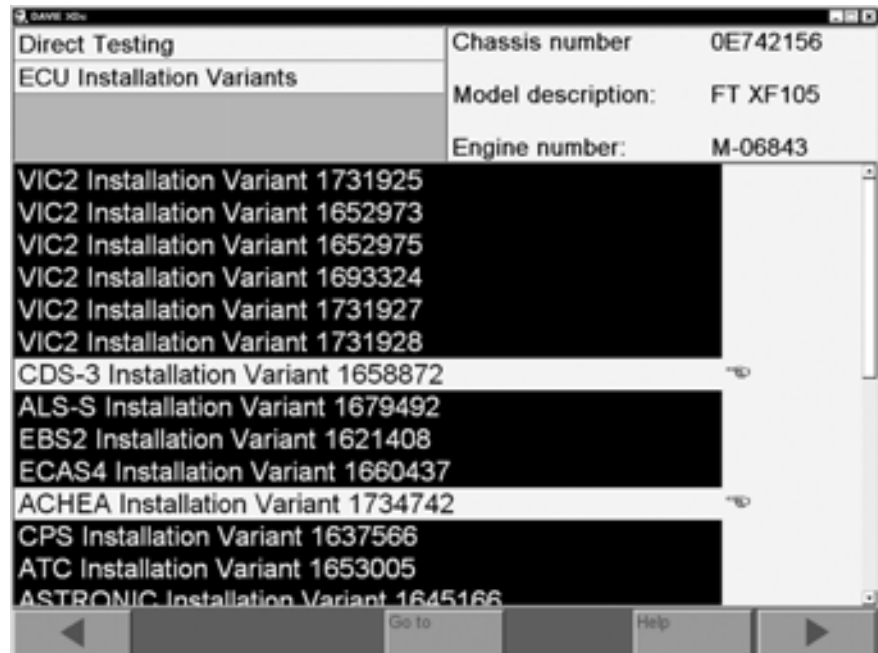

Figure 5-8 System variant list (deselected Variant)

The variant names are displayed. Now it is possible to deselect and reselect systems and variants from the list.

A selected system is marked by a black bar, a deselected system is marked by "☞" and a highlighted bar. The "☞" is only visible if you select or deselect the variants manually.

NOTE

Deselecting automatically selected variants should be avoided. The use of an incorrect variant has a direct influence on the proposal of test procedures. A selection of a variant different to the proposed variant is only necessary if the installation variant is definitively changed in the workshop and the Parts Rapido Subset database or the central truck ECU is not already updated.

The system continues with the "Forward / >" button.

A list with the systems, selected in the "ECU Installation Variant" screen, will be displayed.

DAVIE XDc II

Vehicle Identification

6 DIRECT TESTING

6.1 Overview

This functionality is primarily used to interrogate and erase ECU fault memory and utilize various in- and outputs, dependant on the relevant test procedures selected. The function "Direct Testing" must also be used for programming and calibrating.

The knowledge and experience of the user is fully utilized, enabling the "Direct Testing" to provide a "short cut" to the suspected fault. This functionality supplements the "Guided Diagnostics" facility, ensuring the most efficient route to the fault remedy.

The results of the diagnostic session and manually saved information will be stored in a log file, which can be read out in the Administrator menu.

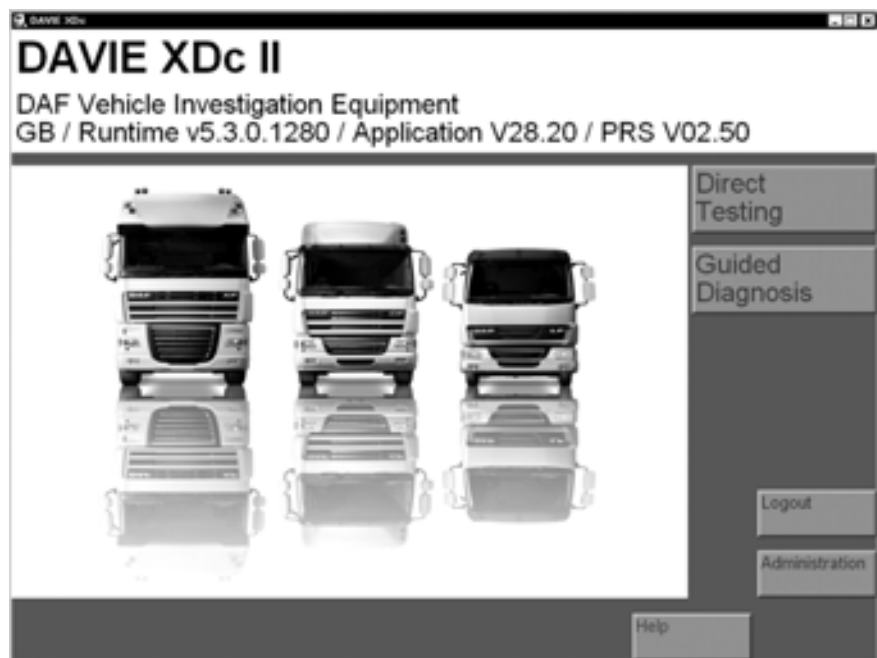

Figure 6-1 Start screen: User Login

To enter the Direct Testing mode, press the "Direct Testing" button on the "Start" screen.

6.2 Vehicle Identification

Whichever diagnostic function is selected in the Start screen (Direct Testing, Guided Diagnosis), DAVIE XDc II will attempt to identify the vehicle and the system variants automatically by using the chassis number and the Parts Rapido Subset database in the DAVIE XDc II.

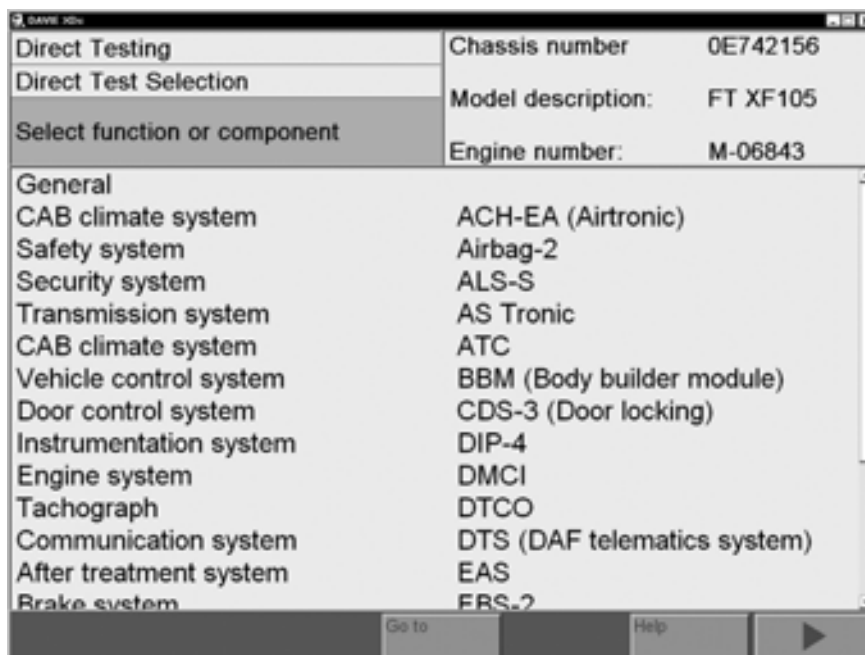

Figure 6-2 Direct Testing: test selection

By continuously selecting from the displayed options, the user can refine the selection until the desired vehicle test procedure is displayed. A system has been selected in the following example. Once this option is selected, more options are displayed.

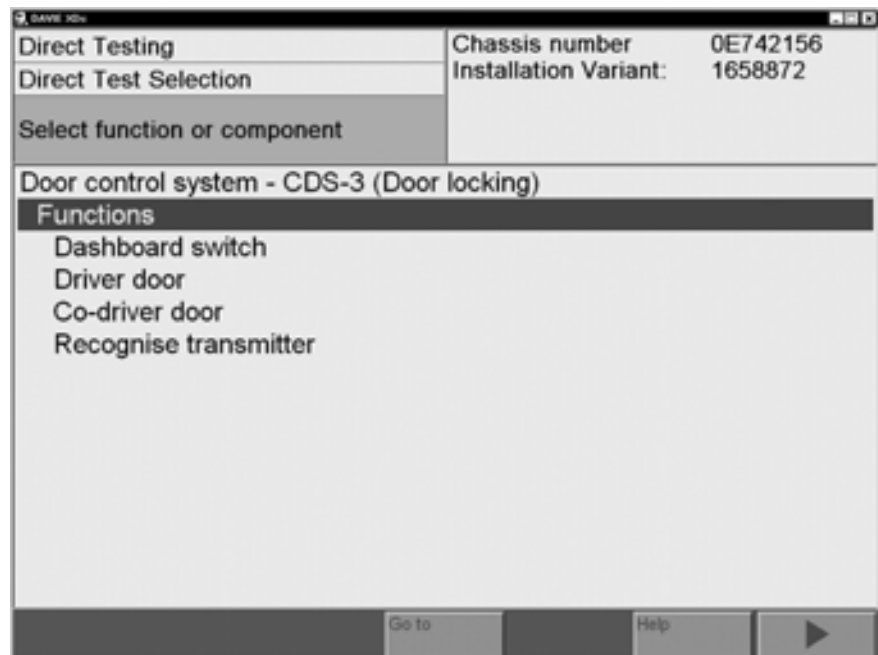

Figure 6-3 Direct Test: procedure selection

To start a selected test procedure, the "Forward / >" button must be activated. If there is no test procedure available, a message will appear. By selecting a procedure with sub-procedures, a sequence of the procedures will be started.

6.3 Executing test procedures

After activating the "Forward / >" button, the selected test procedure will be executed.

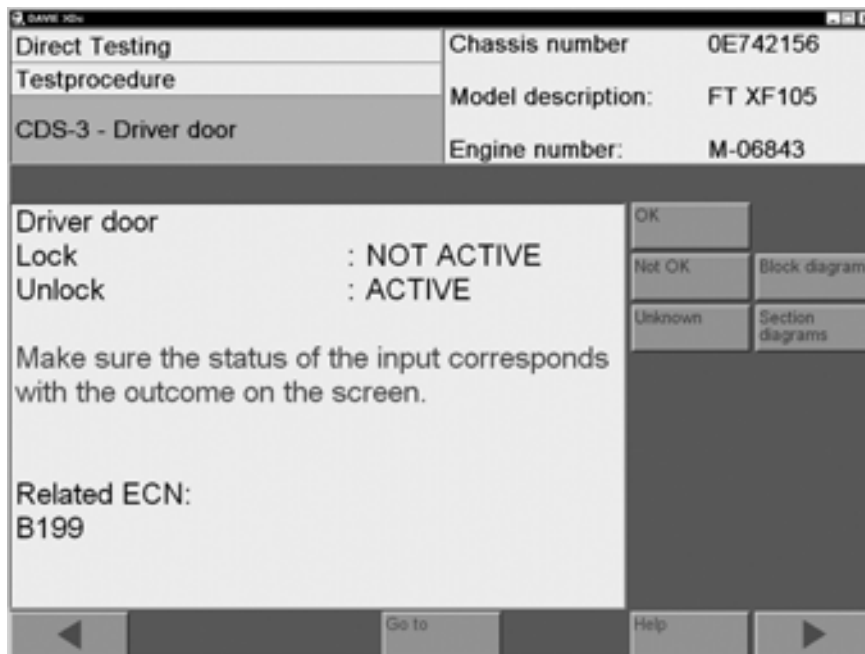

Figure 6-4 Example of test procedure screen 01

For the functionality of the navigation bar, refer to the explanation of the navigation bar in this chapter.

The button or buttons on the right side of the screen must be used to answer questions related to the test procedure (OK, Not OK or unknown) or to open a document (Block- or Section diagram).

- Use the "OK" button when the value or information on the screen is correct according the workshop documentation.
- Use the "Not OK" button when the value or information on the screen is not correct.
- Use the "Unknown" button when the value or information on the screen can not be judged.

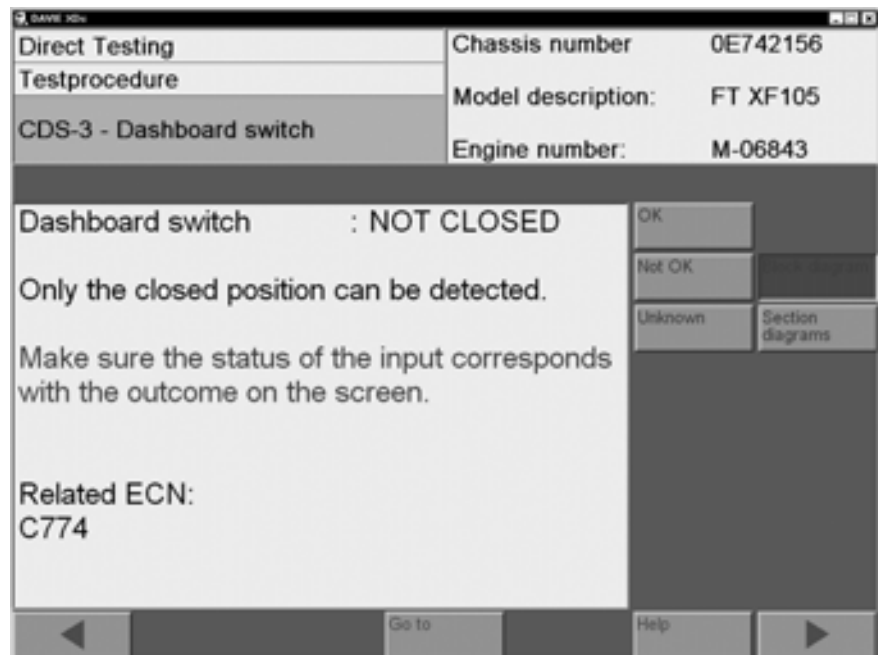

Figure 6-5 Example of test procedure screen 02

NOTE

Use the "OK, Not OK or unknown" button to exit the test; otherwise the test is not closed. Do not use the "back / <" button to exit the test.

NOTE

The system is intelligent and tracks the user selections. The test results are saved in the log file and Test Plan.

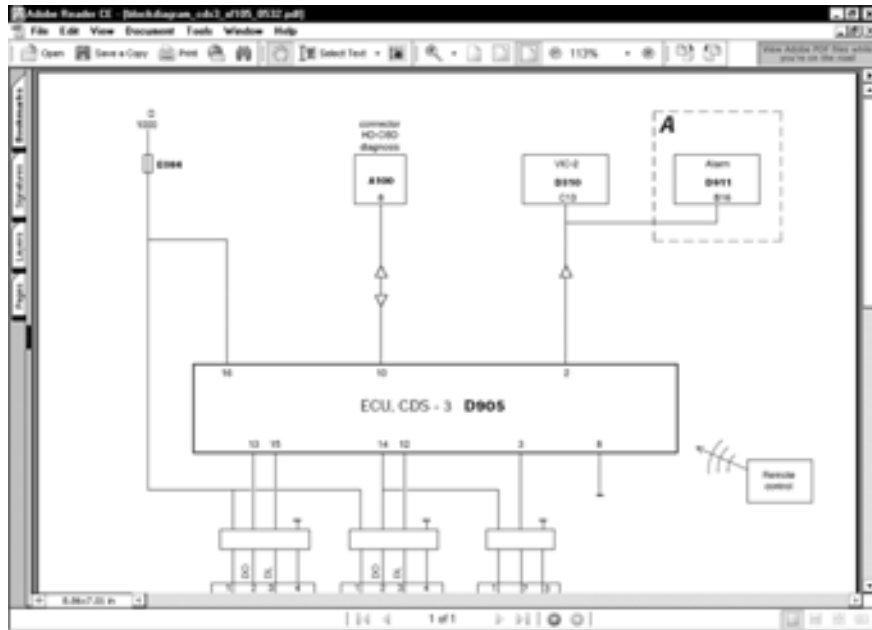

Figure 6-6 Example of a block diagram

6.4 Navigation bar

By pressing the "Navigation Bar" buttons, the user can quickly navigate to various parts of the program. The buttons "Go To" and "Help" contain Windows type "pull up" menus which are screen sensitive and whose contents change according to the screen currently being displayed.

The two "Arrow" buttons ("Back / <" and "Continue / >") allow the user to move forwards and backwards between screens.

If the "Back / <" button is pressed to exit a test, the test remains as running.

6.5 Go To button

During "Direct Testing", various options are available to the user in the pop up menu of the "Go to" button. The contents of the "Go To" menu is dependent on the actual screen. Some examples are listed below:

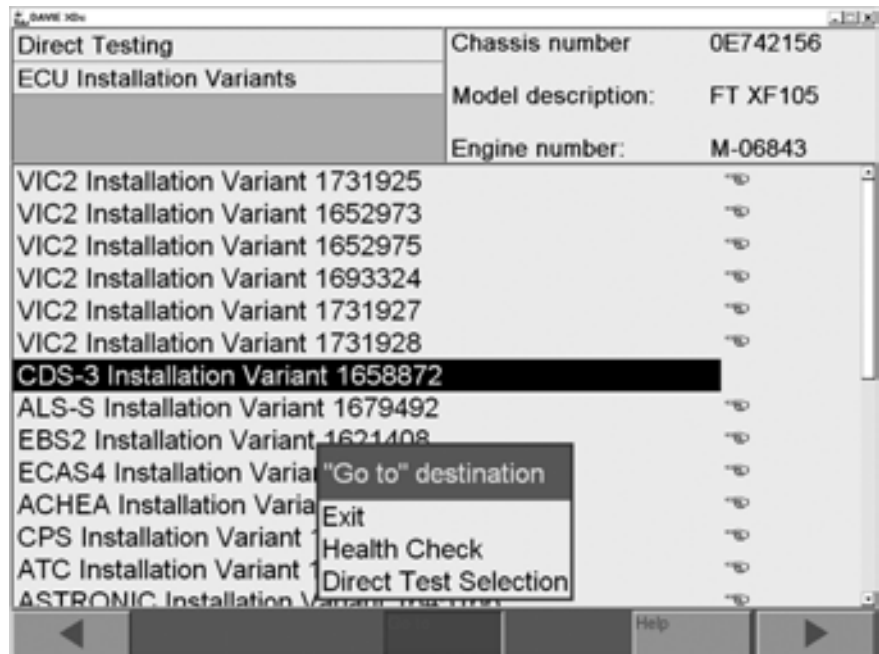

Figure 6-7 Variant: selection screen

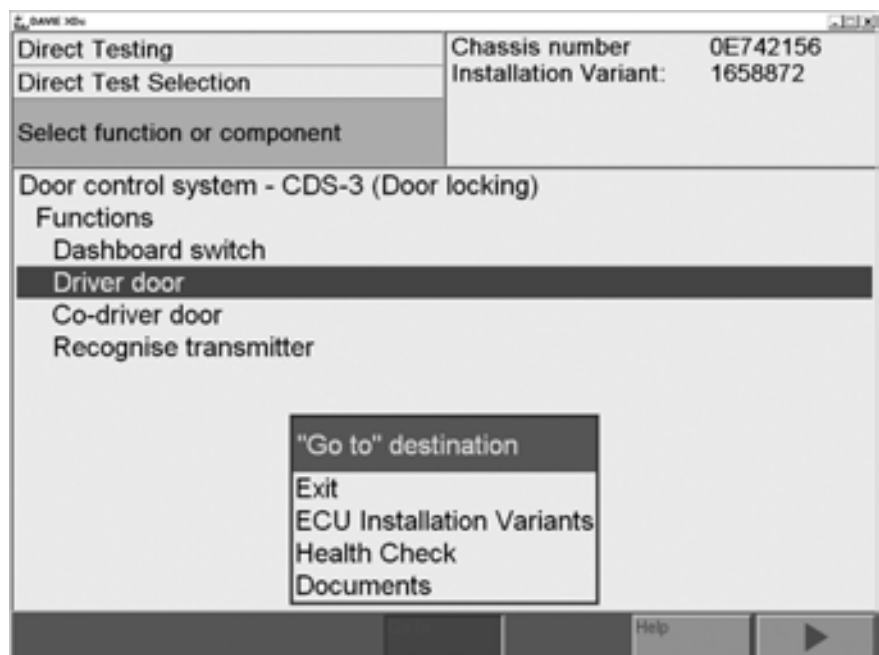

Figure 6-8 Test procedure: selection screen

DAVIE XDc II

Direct Testing

6.5.1 EXIT

This option exits the current test, ends the diagnostic session, and displays the DAVIE XDc II start screen Figure 6-1.

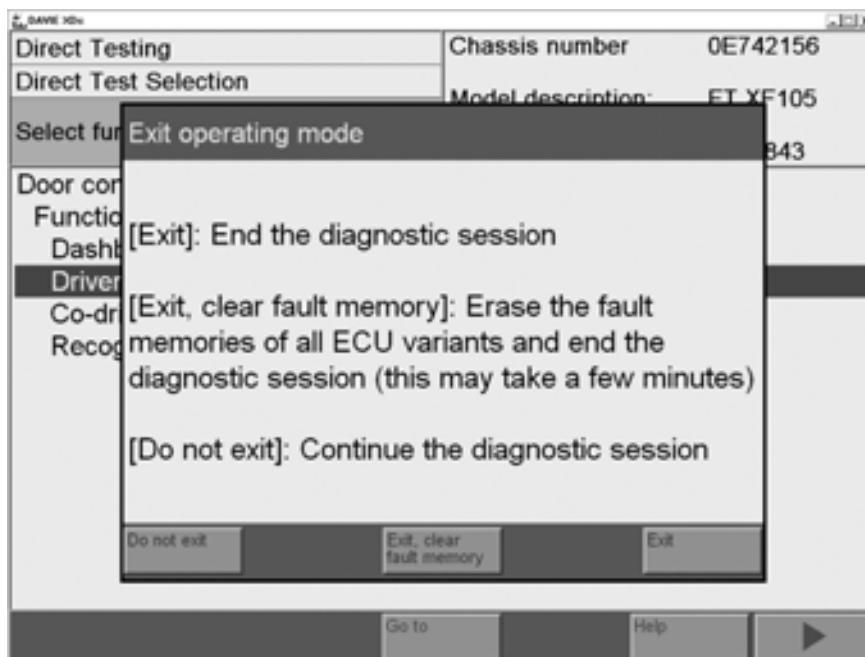

Figure 6-9 Warning : Exit operation mode

6.5.2 Health Check

The option "Health Check" is only displayed within the "Go To" button in the "ECU Installation Variants" and "Direct Test Selection" menu if an ECU is selected.

This option reads all pending (active) fault codes within the system of all selected ECU's in the "ECU Installation Variants" screen.

A "Health Check" is often the first test that is performed because the results provide important diagnostic information that can guide further diagnostic testing.

6.5.3 Fault Memory Contents

All faults which have been detected with the "Health Check" can be read out in the "Fault Memory Contents".

These fault codes are very important for the user because almost every ECU is capable of self-diagnosis and checks the sub-systems connected to the ECU. This information allows the user to concentrate on the specific fault areas in the vehicle.

The results of the "Fault Memory Contents" will be saved into the log file.

6.5.4 Documents

During testing, various documents can be displayed, such as drawings for connectors, wiring diagrams or even instruction sheets. These documents are "linked" to the system at relevant points during testing. For example, if a test is being performed on a connector, a schematic of this connector, showing the various pin connections, could be viewed.

The documents can be displayed via the "Go to" button when the system is selected and by the buttons on the right side of the screen when available.

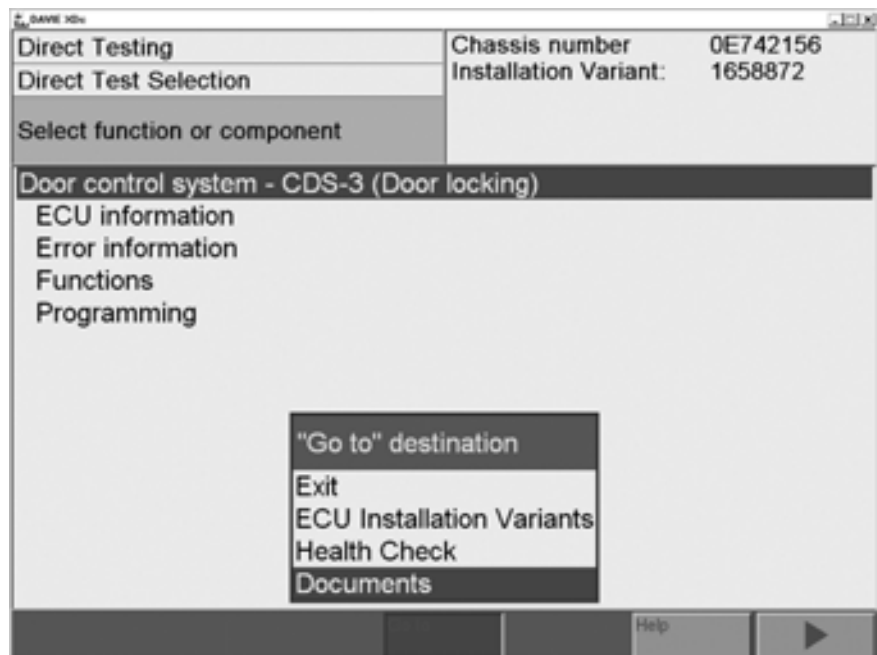

Figure 6-10 Open Documents

6.5.5 Test Plan

The test plan shows the list of the test procedures that have been executed.

The option "Test plan" is available during a diagnostic session. This plan is organized by the DAVIE XDc II to provide useful information guiding the user to a correct diagnosis as quickly as possible. The "Test plan" and the results will be saved into the log file.

An example of a test plan shows the listing of the tests that have been executed.

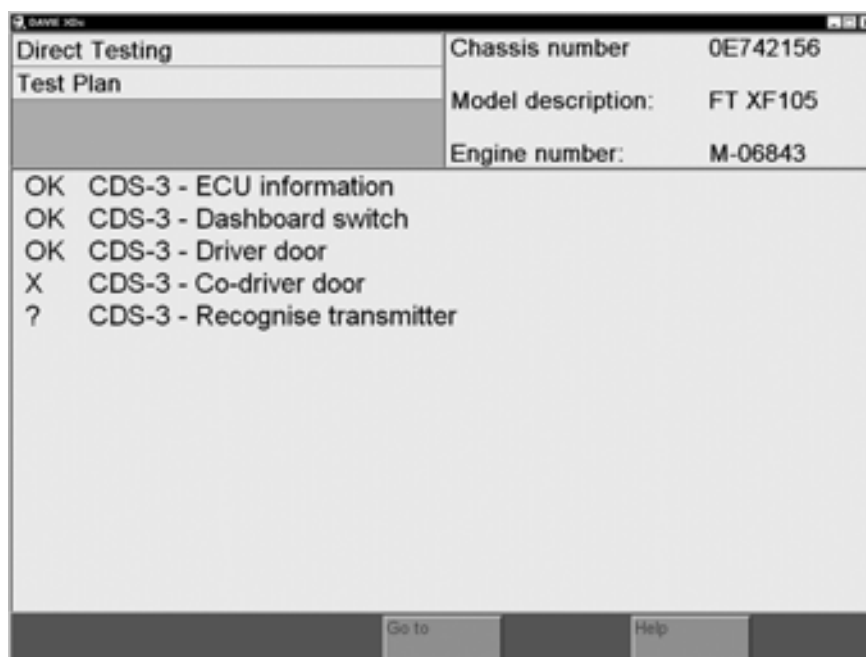

Figure 6-11 Test plan

The user can select which part of the plan to execute next by pressing a particular test, which will then be performed when the "Forward / >" button is pressed.

The result of the test procedure is noted in front of the line. The following results are possible:

1. **OK** The test procedure was completed with the result OK.
2. **X** The test procedure was completed with the result Not OK.
3. **?** The result of the test procedure is unknown or the procedure was interrupted. For example the test was closed by using the back button.

6.5.6 ECU Installation Variants

This option within the "Go To" menu on the Navigation Bar allows the user to return to the screen which list the ECU options found for the vehicle.

6.5.7 Direct Test Selection Screen

Use this function in the "Go To" menu to switch back to the "Direct Test Selection" and to select another system. The diagnostic session will be not completed and all previous test results will be available until the "Direct Test" function is terminated by using the "Exit" function.

6.6 Use of illustrations

During testing, various documents can be displayed, such as drawings for connectors, wiring diagrams or even instruction sheets.

These documents are "linked" to the system at relevant points during testing. For example, if a test is being performed on a connector, a schematic of this connector, showing the various pin connections, could be viewed.

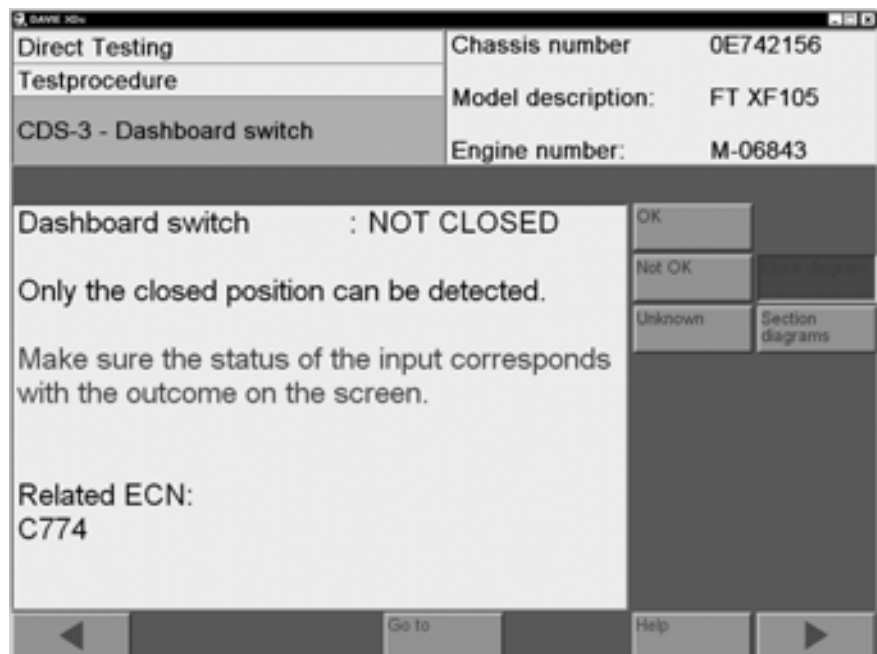

Figure 6-12 Selection of block diagram button in "Direct Test"

By pressing the corresponding button, "Adobe Acrobat®" will start up separate of the DAVIE XDc II program. An index page could appear before the illustrations are displayed.

DAVIE XDc II

Direct Testing

6.6.1 Index page

In the index page the chassis number can be selected for the appropriate illustrations.



Figure 6-13 Example of an "Index Page"

All blue items have a link to illustrations.

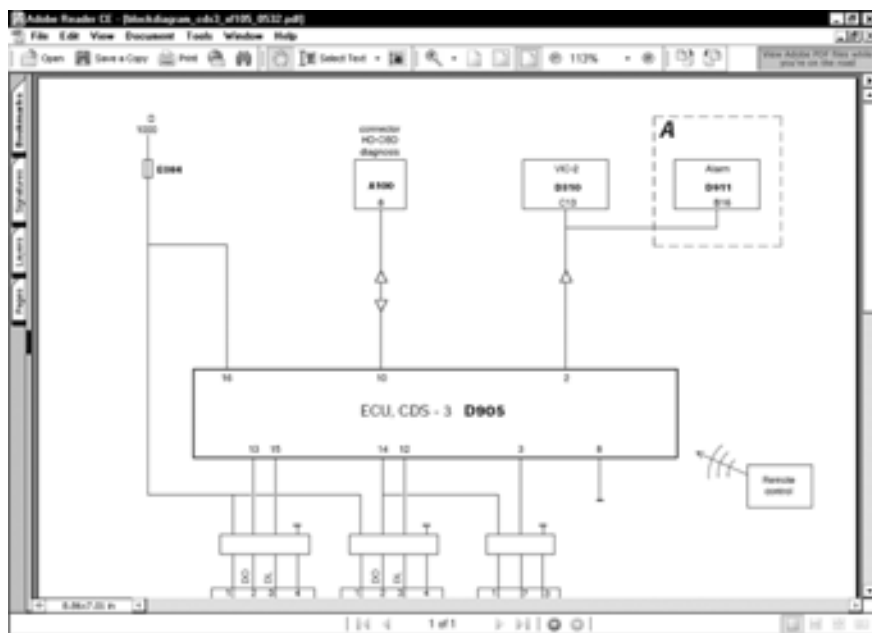

Figure 6-14 Example of a "Block diagram"

6.6.2 Explanation of buttons on the screen

The buttons can be divided in two categories:

1. Actions on one document concerning zoom functions
2. Actions between documents

Actions between documents

Green round arrows at the bottom of the screen:

With this buttons the previous document can be entered in the list of documents which were already open.

Bleu arrows at the bottom of the screen:

With these buttons you can switch between documents which are already open.

Zoom functions

Zoom:

At the top of the screen a navigation bar is displayed.

When the magnifying glass is pressed the zoom function is selected.

You can enlarge the desired area by dragging a zoom window on the screen.

When the arrow near the magnifying glass is pressed you can choose some zoom options.

For further information about the functions in Adobe Acrobat, please use the "Help function" of Adobe Acrobat.

7 GUIDED DIAGNOSIS

7.1 Principle op of Guided Diagnosis

Guided Diagnosis is primarily used to determine (point out) the possibly defective elements (components). Where the function "Direct Testing" has to be used for programming, calibrating or to directly test specific components, "Guided Diagnosis" presents tests only based on the elements which are suspected to be defective.

Why using Guided Diagnosis?

- If you want to confirm suspicion without exchanging parts by trial & error
- If you don't know which components to suspect
- If you have a lack of knowledge about a vehicle function
- If an error status is unclear (active/not active) symptoms can be used
- Guided can and will tell you!

There are different methods, within Guided Diagnosis, to find the suspected element (component):

1. Based on Fault codes (present in the ECU Fault Memory)
2. Based on Symptoms (deviant behaviour of Systems)
3. A combination of above

The best way to build a Test plan is using Fault codes (1), because this usually generates a **small** list of suspected elements.

When no Fault codes are present the Test plan can be build on Symptoms (2). The list of suspected elements can be much larger.

When Fault codes are present, but the list of suspected elements is still very large, Symptoms can be added to decrease the list (3).

DAVIE XDc II

Guided Diagnosis

7.2 Starting Guided Diagnosis

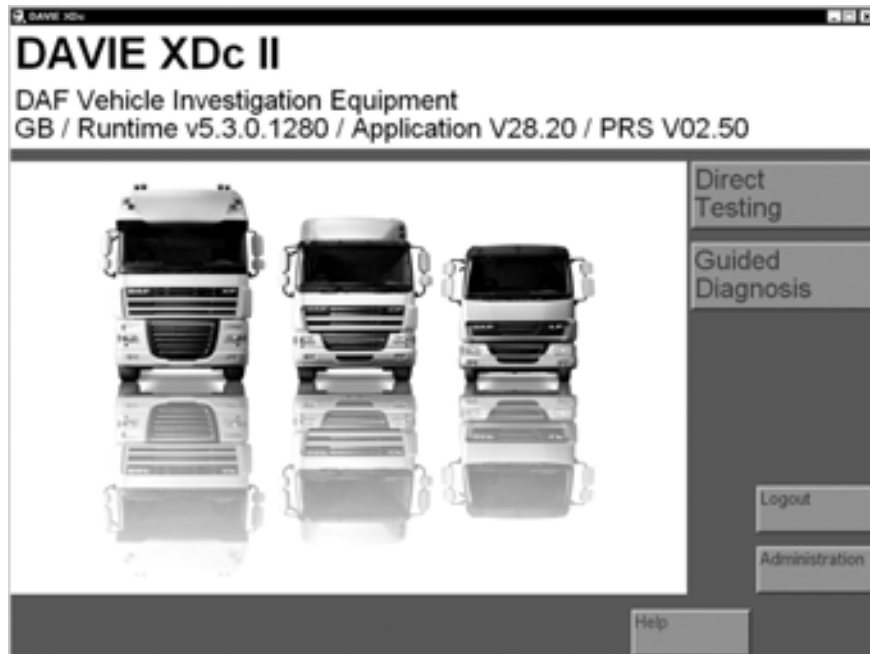

Figure 7-1 Start screen User Login

To enter the Guided Diagnosis Mode press the "Guided Diagnosis" button on the "Start" screen.

7.3 Vehicle Identification

Whichever diagnostic function is selected in the Start screen (Direct Testing, Guided Diagnosis), DAVIE XDc II will attempt to identify the vehicle and the system variants automatically by using the chassis number and the Parts Rapido Subset database in the DAVIE XDc II.

For detailed information about vehicle identification, refer to the chapter "Vehicle Identification" in this manual.

7.4 Guided Entry

There two different main methods to build a test plan to solve the problem on the truck.

Guided entry with:

- Fault codes (present in the ECU Fault Memory)
- Symptom (deviant behaviour of the truck)

Select the entry you want to use and it turns press the "Forward / >" button

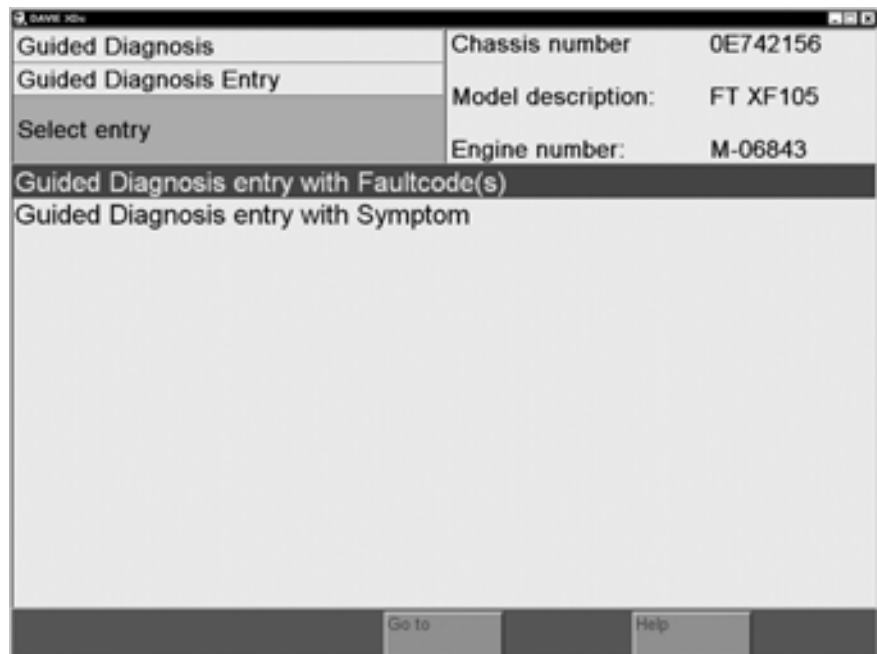

Figure 7-2 Guided Entry

7.5 Guided entry with Fault code(s)

This method uses the fault codes, present in the ECU Fault Memory, to determine which elements are suspected to be defective.

To read out all Fault codes, press the "Guided entry with Fault codes" in the "Guided Diagnosis Entry" screen. After this selection the "Health Check" is started automatically.

DAVIE XDc II

Guided Diagnosis

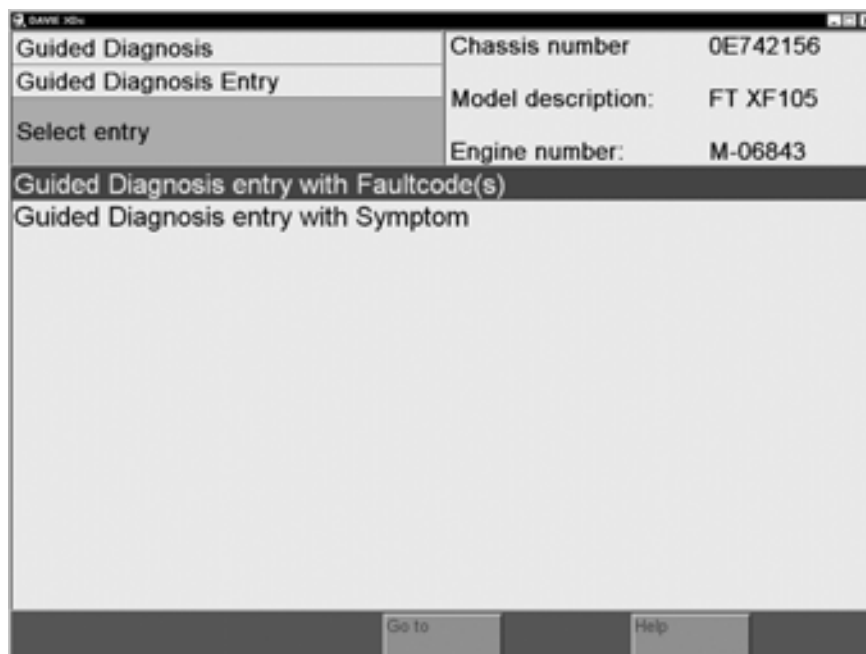

Figure 7-3 Health Check

7.5.1 Health Check

The "Health Check" reads out all present Fault codes from the ECU fault memory for all selected Systems, which are available on the vehicle.

When the ECU is being read out a "<==>" will be displayed in blue colour on the screen.

When fault codes are read, the text "Fault" will be displayed in red colour behind the system.

When fault codes are read from the ECU, but no present Fault codes are found, a "√" will be displayed in green colour.

When fault codes are not implemented in the ECU, it will remain blank.

Press the "Forward/ >" button to go to the Test plan Overview.

NOTE

- Only Pending errors are used by Guided Diagnosis.
 - When no Fault codes are present the Test plan cannot be build. Therefore Guided Diagnosis will automatically switch over to Symptom selection
-

7.6 Guided entry with a Symptom

This "Symptom Based" method uses the selected symptom to determine which elements (components) are suspected to be defective.

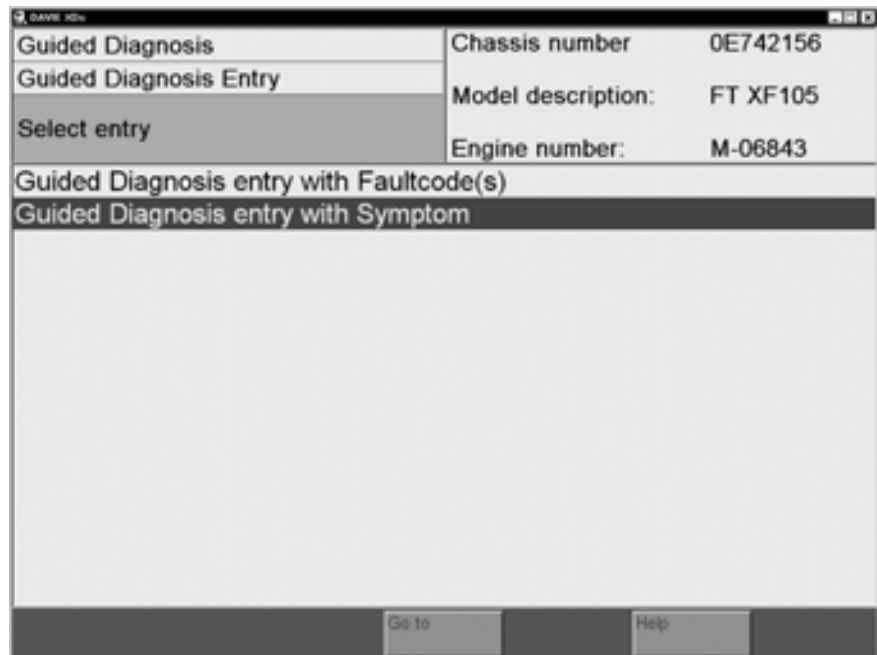

Figure 7-4 Symptom selection based on repair group or observation

When "Symptom Based" the first option is chosen, a list of "Vehicle function based symptom" tree is displayed.

- Driveline: Generate / transmit / convert driving and braking power to achieve desired velocity
- Chassis: Carrying and handling the load / directing the vehicle / exterior lighting / body building
- Cabin: Driver working & living environment
- General: Fuses and communication

DAVIE XDc II

Guided Diagnosis

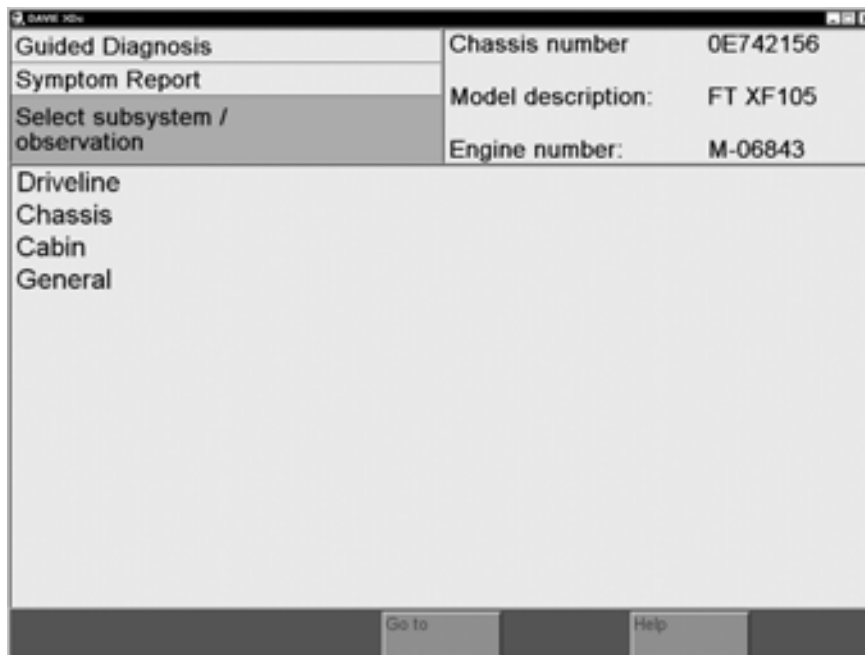

Figure 7-5 Systems with Symptoms for Guided Diagnosis

When the group of choice is selected the list will unfold to an overview of "Symptoms" or "Symptom groups".

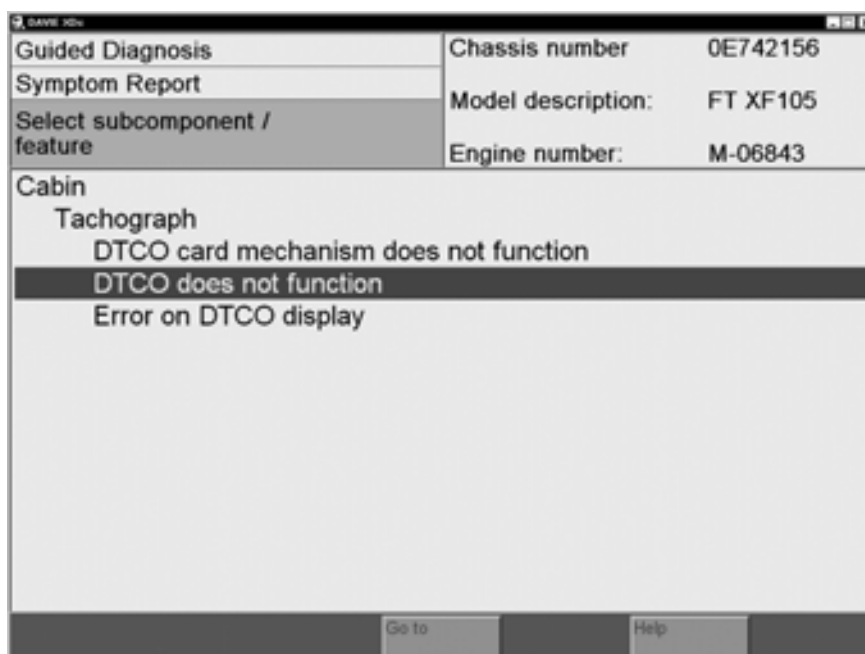

Figure 7-6 Select Symptom

The "Forward / >" button will appear at the bottom of the screen. Now it is possible to add the selected symptom to the "Test plan".

Once the Symptom is accepted it is placed in a list, called the "Test plan overview".

7.7 Test plan

7.7.1 Test plan Overview

All detected faults or selected symptoms are displayed on this screen
Select the (grouped) fault or symptom you want to solve.

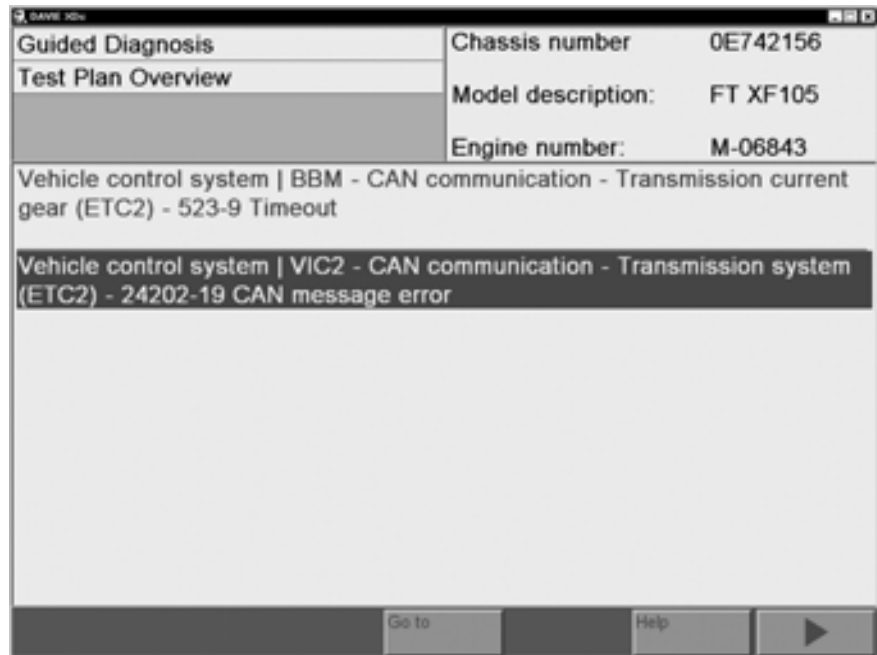

Figure 7-7 Test plan Overview after "Health Check"

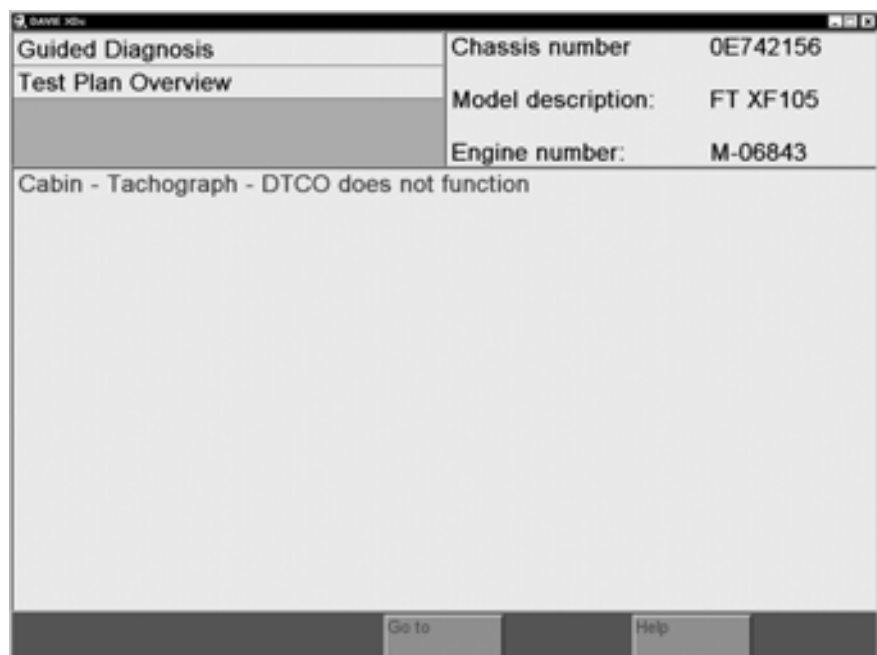

Figure 7-8 Test plan Overview after symptom selection

DAVIE XDc II

Guided Diagnosis

Once the selection is made, press the "Forward/ >" button. Guided will be configured to set up the tests.

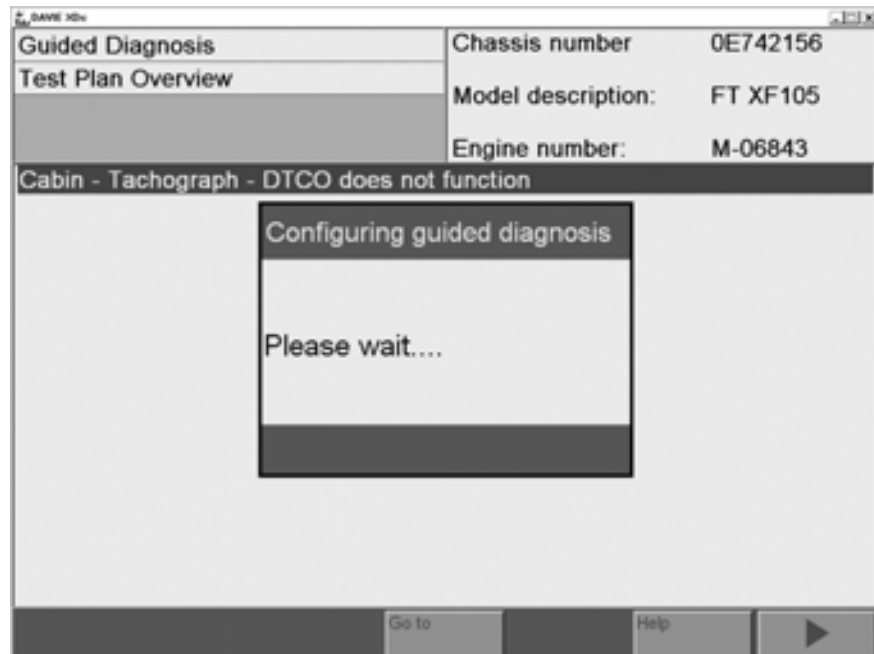

Figure 7-9 Configuration of Guided Diagnosis

7.7.2 Building a Test plan based on Fault codes and Symptoms

This method uses not only the read out Fault codes but also extra selected Symptoms to determine which elements are suspected to be defective.

To add Symptoms press the "Go to" button on the navigation bar and select "Symptom Report".

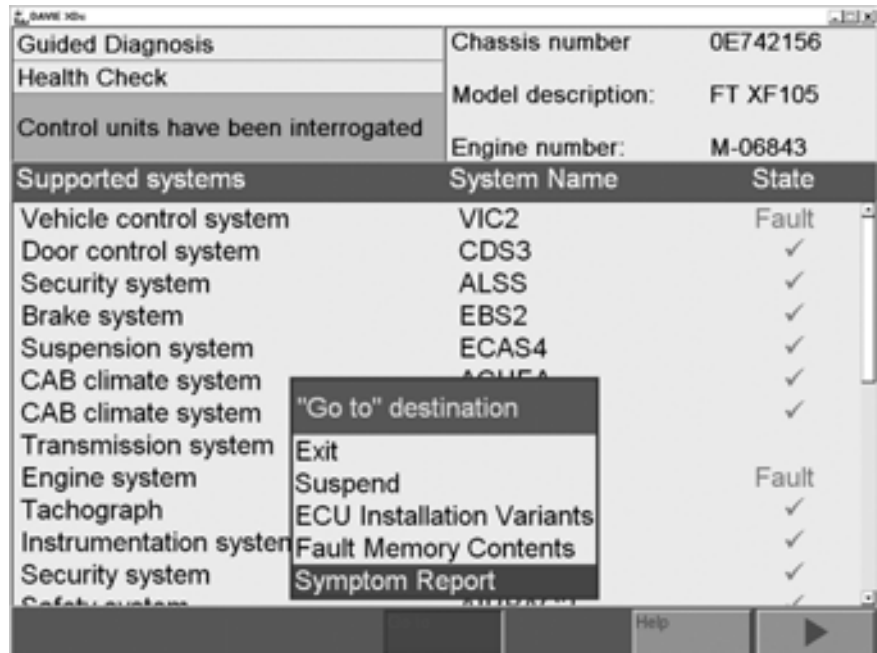

Figure 7-10 Select Symptom Report

7.7.3 Test plan screen lay out

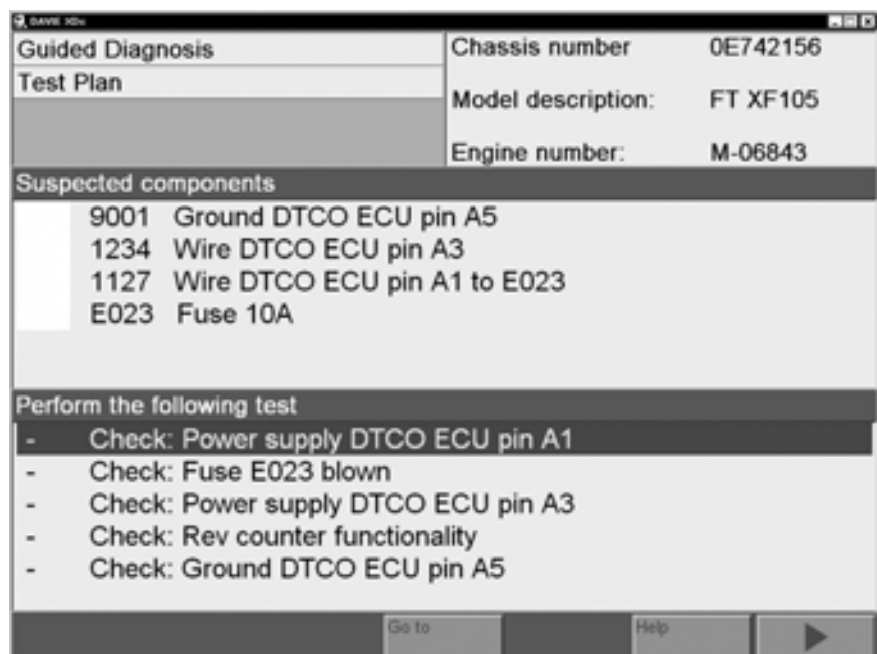

Figure 7-11 Test plan

DAVIE XDc II

Guided Diagnosis

The screen is divided in two sections:

- The upper half displays the Suspected Elements
Which elements are suspected is purely based on the read out Fault codes and selected Symptoms. The elements are sorted on the level of suspicion; the most upper element is the most suspected.
- The lower half displays the proposed tests
The list is based on the sequence and availability of the tests, which are best to be executed. Generally the most upper test is the most effective test (the user is obviously free in selecting any other test of the list).

The level of suspicion is also indicated by use of colours.

Dark red	Faulty (tested)
Red	Very suspected
Yellow	Suspected
Green	Ambiguous

Figure 7-12 Suspicion level of components

The result of the test procedure is noted in front of the line. The following results are possible:

- The Test procedure is not yet executed.
- OK** The Test procedure was finished with the result OK.
- X** The Test procedure was finished with the result not OK.
- ?** The result of the Test procedure is unknown or the procedure was interrupted.

7.7.4 Executing tests

Proposed tests occur in different forms.

1. Direct Test
2. Symptom test or Check test
3. Measurement test

When the test result is

- Correct: press "OK"
- Incorrect: press "Not OK"
- Uncertain: press "Unknown".

NOTE

It is very important for Guided Diagnosis that the answers and implicitly at the end of the test is corresponding with the vehicle behaviour.

Incorrect answers will lead to a different suspected element.

7.7.4.1 Direct test

When a Direct Test will be proposed, the same test as used for Direct Testing will be used to determine the defectiveness of a component.

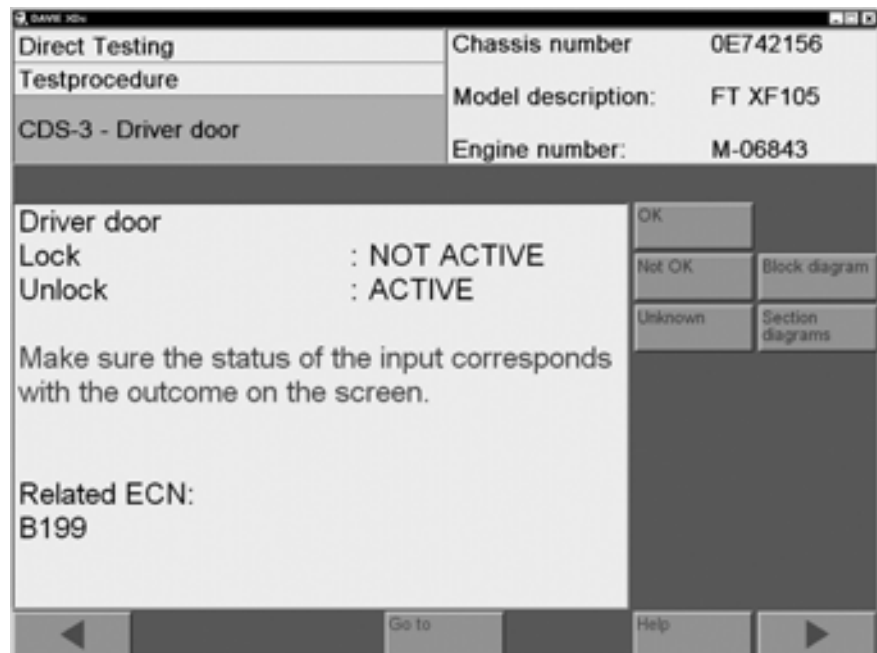

Figure 7-13 Example of a Direct test

7.7.4.2 Symptom test or Check test

When a test is proposed to check a symptom, Guided Diagnosis would like to have more information on the vehicle behaviour. It will require some actions from the user and will ask if the behaviour of the vehicle was as expected when these actions were executed.

DAVIE XDc II

Guided Diagnosis

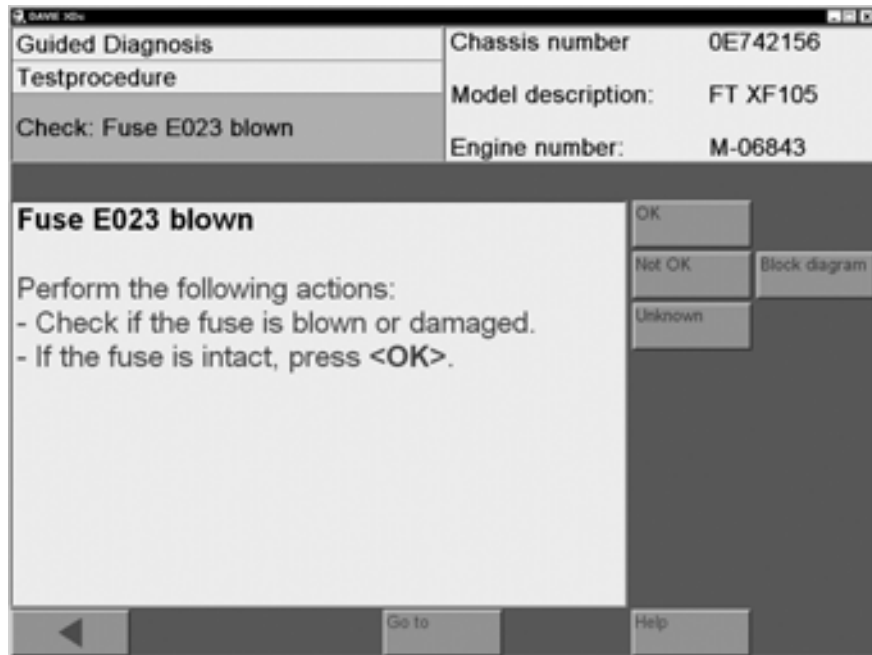

Figure 7-14 Test to research presence of Symptom

7.7.4.3 Measurement Test

When a measurement test is proposed, Guided Diagnosis would like to have more information on the status of wiring and components. In most cases it would be a test to determine the voltage on a connection.

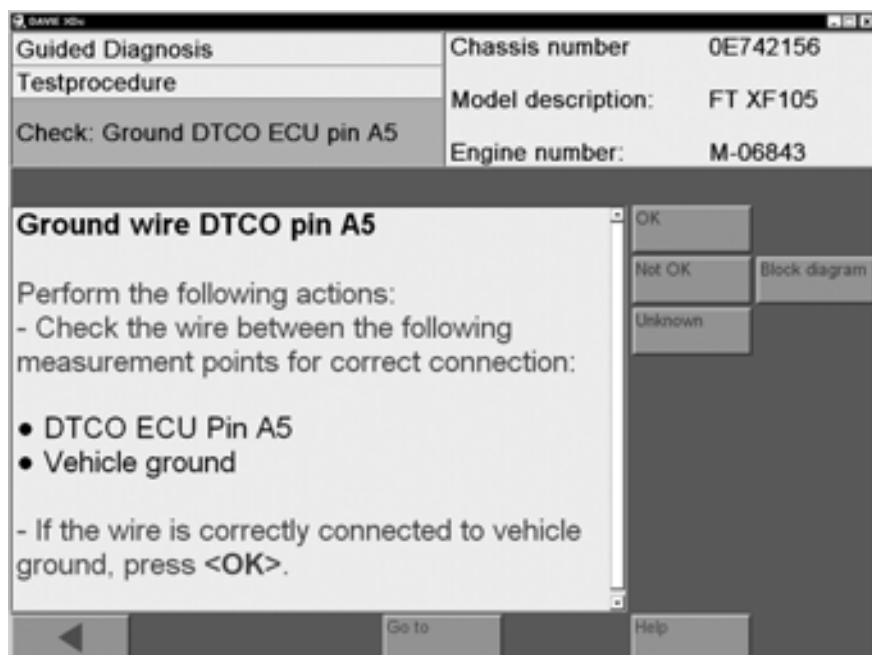

Figure 7-15 Test to research short and / or open circuits

7.7.5 Function Component selection

With Guided Diagnosis it is also possible to test a component individually or to select a test which is linked to other components than the currently listed in the Test plan. Adding extra information, into the reasoning mechanism, may be useful to guide you quicker to the defect.

To add a Test: press the "Go to" button on the navigation bar and select "Function / Component Selection".

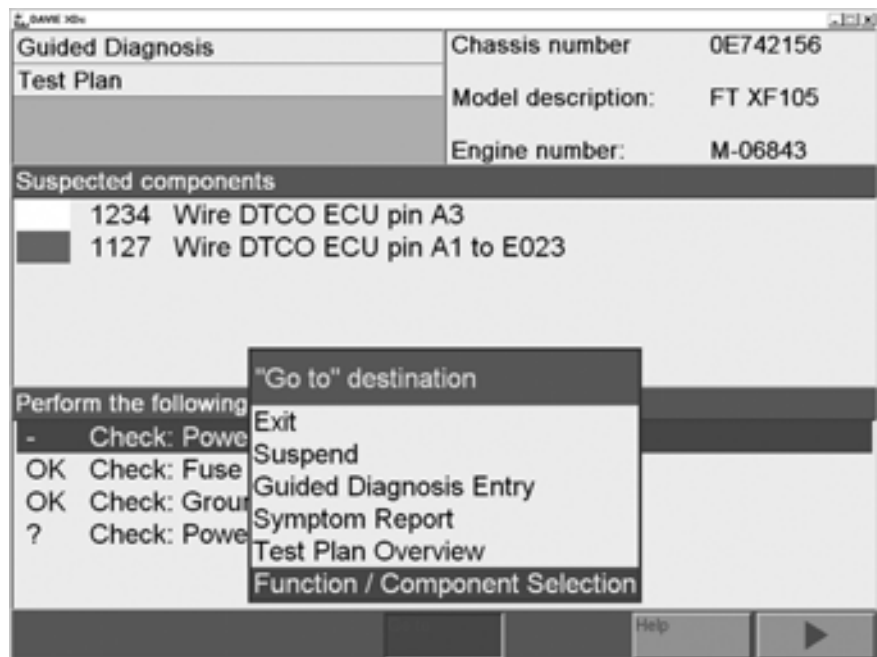

Figure 7-16 Select Function/ Component Selection

After selecting the System of choice a list of linked components, when available, will be displayed.

DAVIE XDc II

Guided Diagnosis

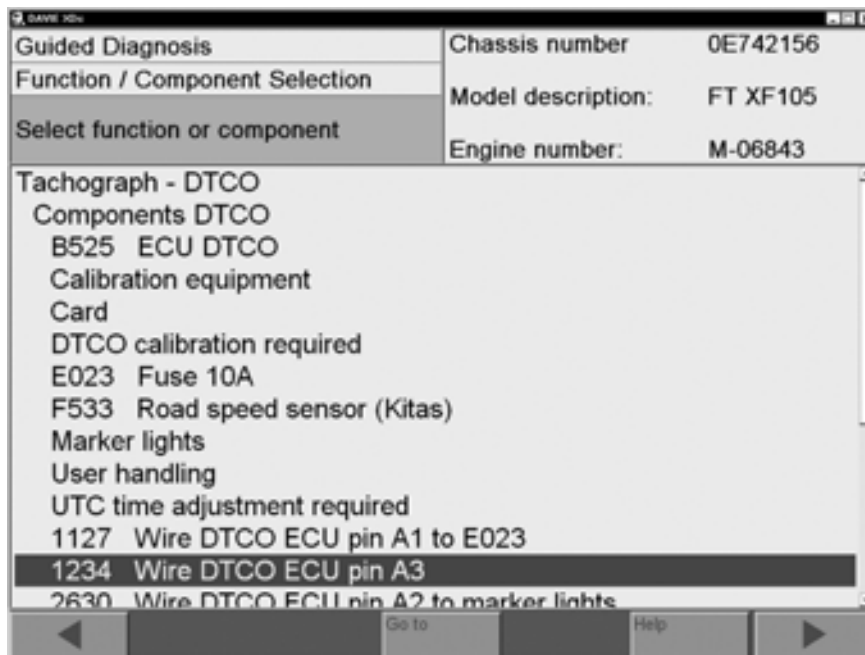

Figure 7-17 List of linked components

From this list any component can be selected. After selecting a component, by pressing the "Forward / >" button in the bottom right of the screen, the User Test plan is added to the Test plan screen.

If more tests are available, a pop-up screen will appear, displaying these tests. In this screen it is possible to select the requested test. When a test is selected, press the "OK" button and the test is added to the user Test plan.

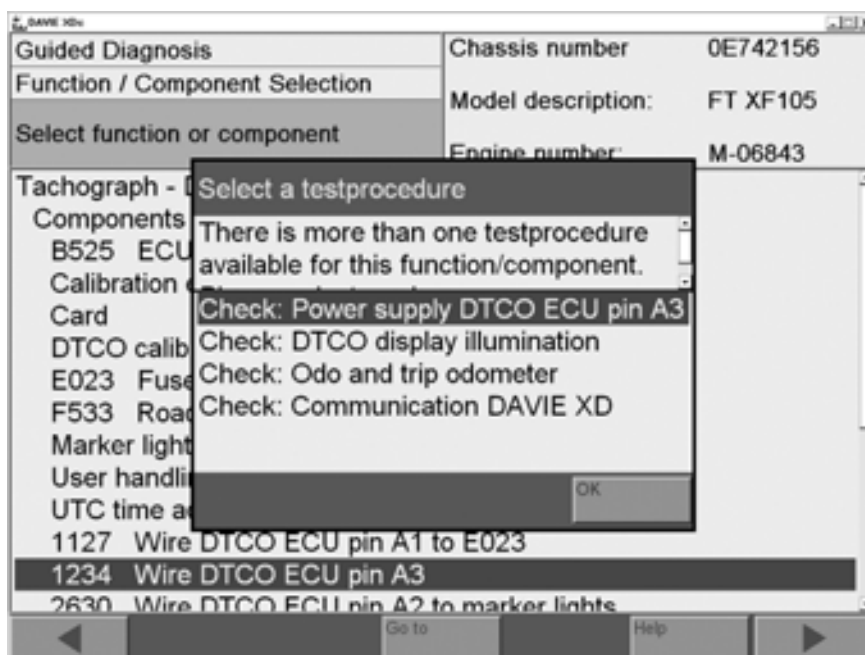

Figure 7-18 Select a test

If there is only one test available for the selected component the user Test plan is started directly after continuing from the component selection screen.

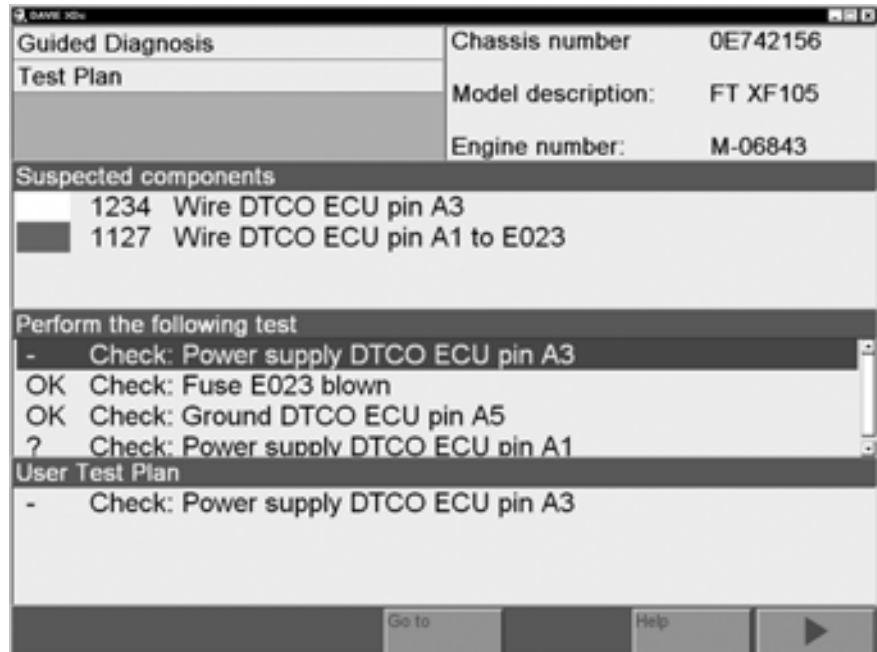

Figure 7-19 Test plan including user Test plan

7.8 Extra options

7.8.1 Fault Memory Contents

When the System, interrogated through the health check contains one or more Fault codes, the contents can be displayed with the Fault Memory Contents. The Fault Memory Contents can be viewed from the "pop up" menu under the "Go To" button.

These Fault codes are very important for the user because almost each ECU is capable of self-diagnosis and checks sub-Systems connected to the unit. This information allows the user to concentrate on the specific fault areas on the vehicle.

DAVIE XDc II

Guided Diagnosis

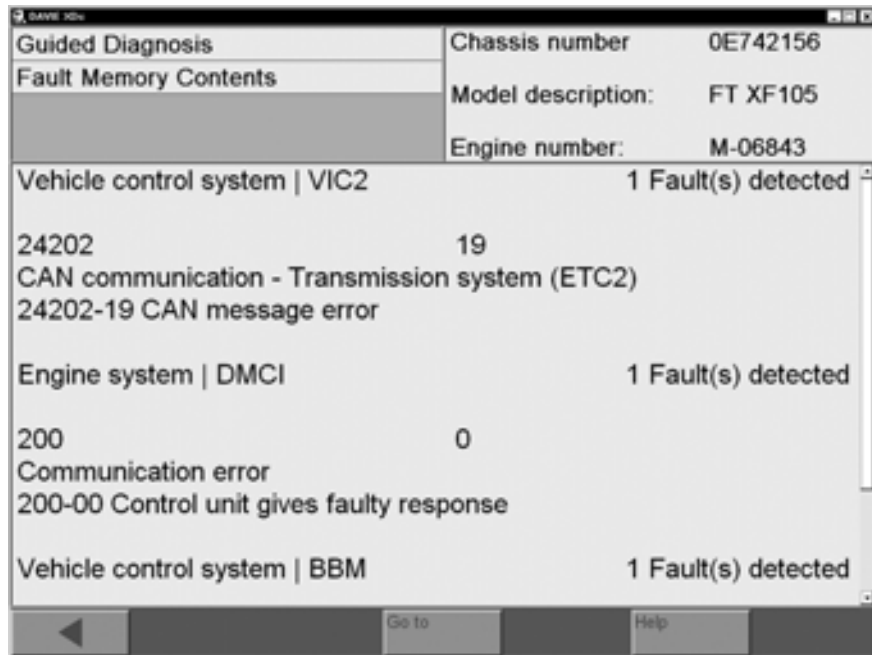

Figure 7-20 Fault memory content

This screen displays the currently present Fault codes. Equal to Direct Testing every Fault code is represent with a Fault code number and text.

7.8.2 Deselecting Systems

In order to leave one or more Systems out of the Test plan, deselect those Systems before performing the Health Check.

This can be useful:

- When a System produces Fault codes, but has no relation to the complaint.
- To speed up Diagnostic sessions, by deselecting those Systems which are not related to the complaint.

NOTE

When Health Check already has performed, without deselecting Systems, Exit and restart Guided Diagnosis via selecting "Exit" from the "pop up" menu button under the "Go to" button then select "Guided Diagnose" in the startscreen.

When the automatic vehicle identification is complete the Guided Diagnosis entry screen is displayed. Use the "Go to" button and select "ECU Installation Variants".

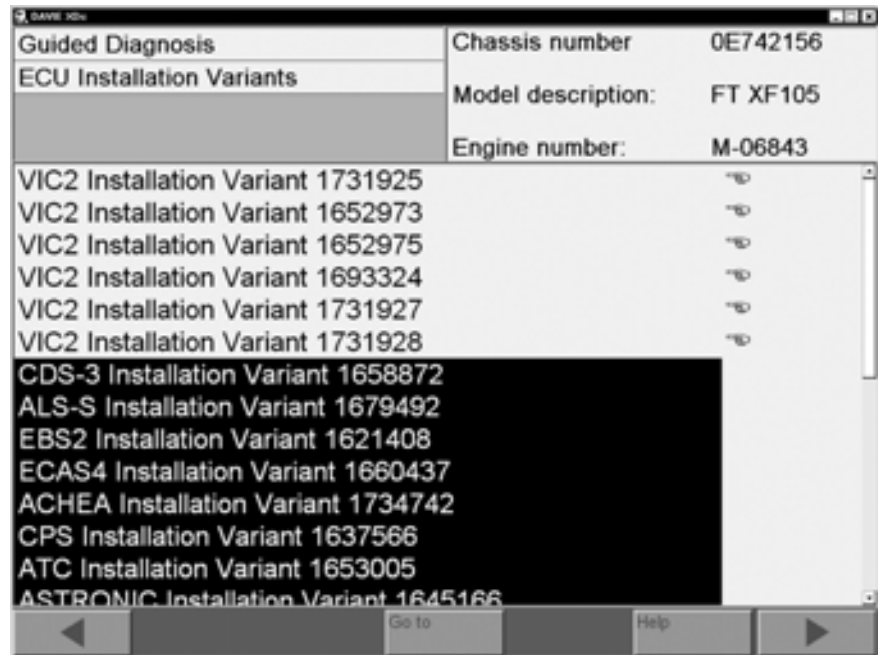

Figure 7-21 Deselected Variant

By touching the variant names, it is possible to deselect and reselect Systems and variants from the list.

A selected System is marked by a black bar and / or "☞".

A deselected System is marked by "☞".

The "☞" is only visible if you select or deselect the variants manually.

7.8.3 Suspend session

When quitting Guided Diagnosis, all gathered information (Fault codes, test results etc.), will normally be lost. Therefore it is possible to save this information.

In a next session it is possible to continue the work from where it was ended.

To save the Guided Diagnosis session select "Suspend" from the "Go to" menu in the Test plan.

DAVIE XDc II

Guided Diagnosis

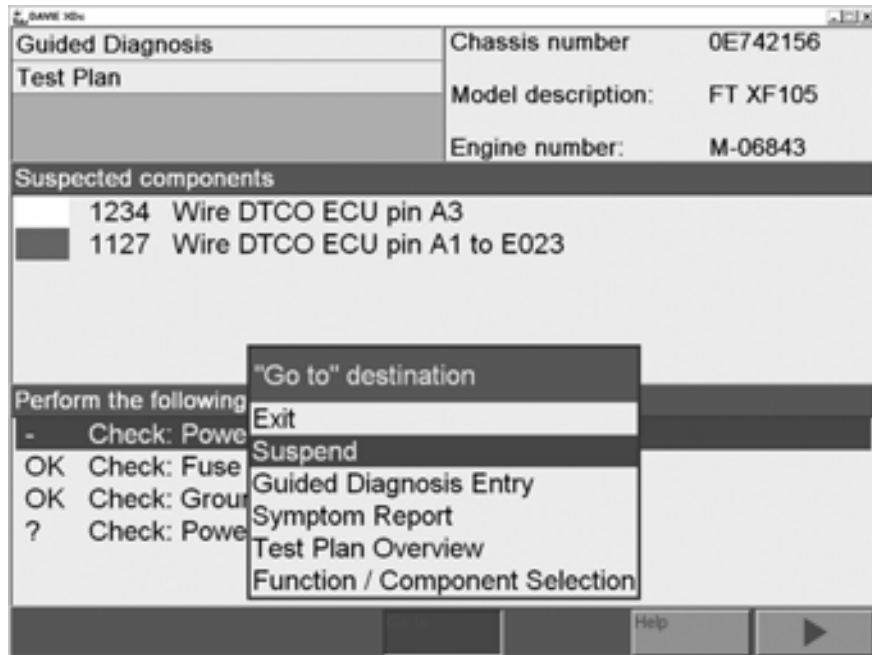

Figure 7-22 Select Suspend

When selecting suspend, a screen will be displayed with the options:

- Pause: This will stop the work only temporarily, and it will not be possible to do anything else, until the pause is ended.
- Suspend: This will save the current diagnostic information, like suspected elements and executed tests, so that it may be started again in the future.

When "Suspend" is chosen, the current diagnostic session is ended.

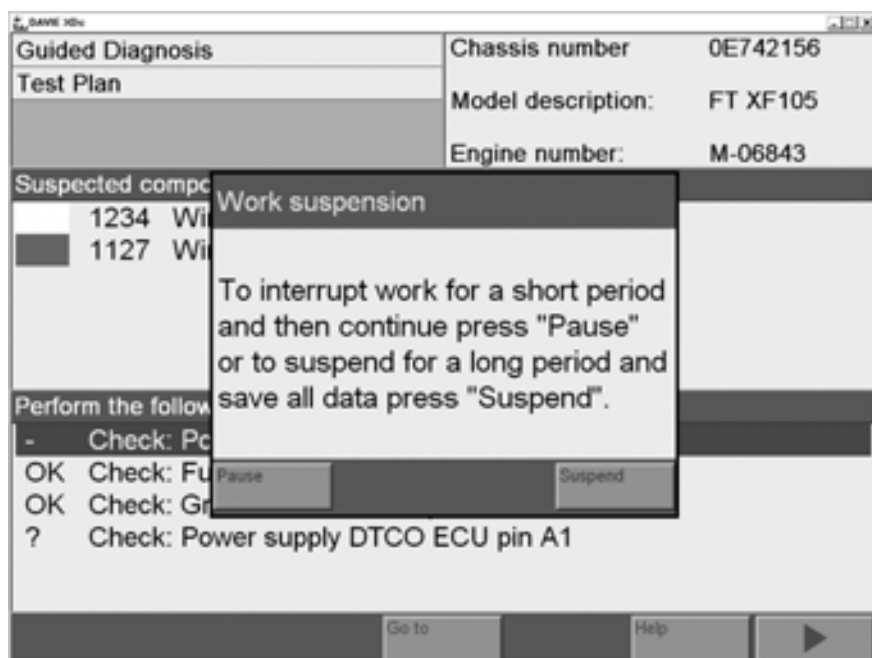

Figure 7-23 Work suspension

To continue with a previously suspended session, it is required to select the option "Diagnosis Job" from the "Go to" menu in the ECU installation variants screen.

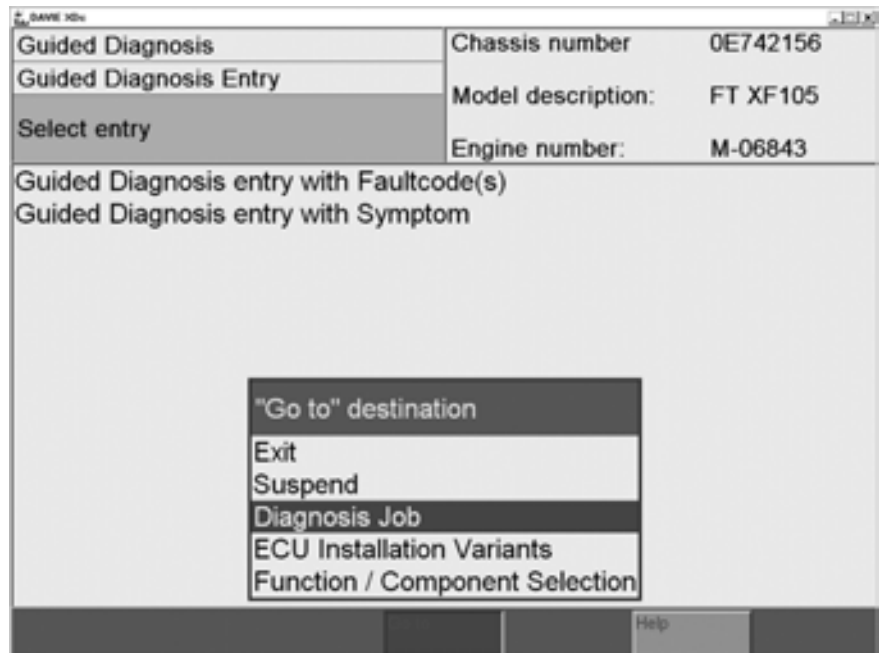

Figure 7-24 Select Diagnosis Job

When selecting "Diagnosis Job", a screen with the diagnostic jobs will appear. By selecting the diagnosis job, it is possible to use or delete the saved session.

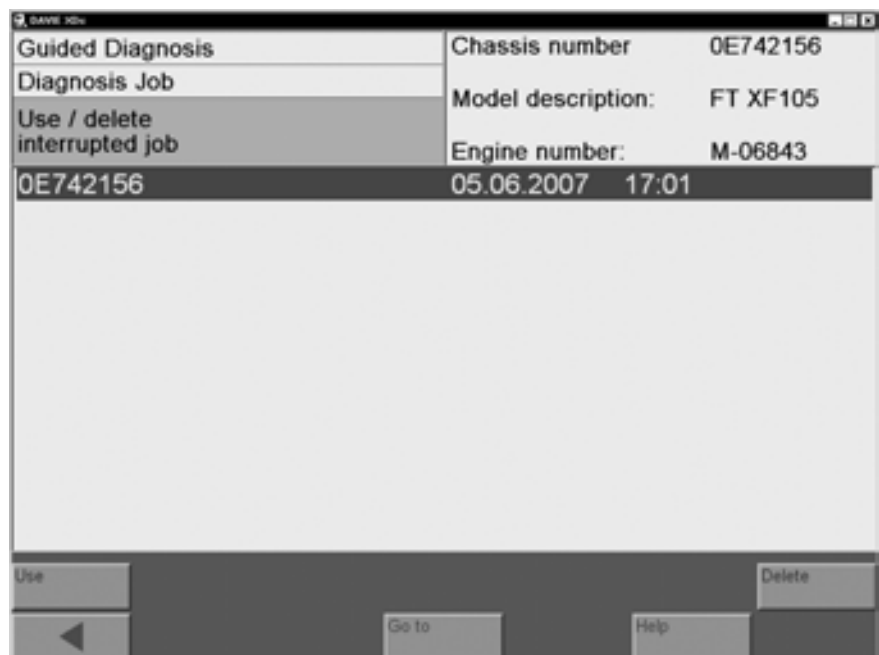

Figure 7-25 Select suspended diagnostic session

DAVIE XDc II

Guided Diagnosis

To delete a session select the required session and press the "Delete" button in the bottom right of the screen.
To continue with the diagnostic session of choice, select it and press the "Use" button in the bottom left of the screen.

When a selection is made a screen will appear indicating that the vehicle must be connected.

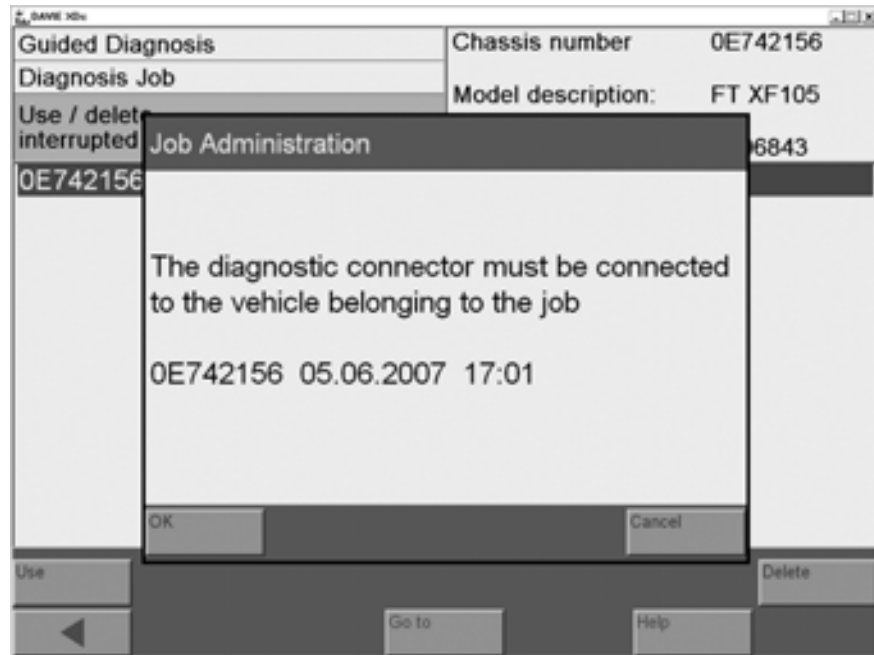

Figure 7-26 Connect DAVIE XD to the correct vehicle

After connecting the DAVIE XDc II to the vehicle, via the VCI, and pressing "OK" in this screen, Guided Diagnosis will continue reasoning from the latest Test plan screen, where Guided Diagnosis was suspended.

When for the second time a session is suspended (for the same truck) press "Repeat" to overwrite the old session, or press "OK" to add this session. The date and time of saving will help to identify the exact session.

Because Guided Diagnosis is based on the principles that a Symptom or Fault code is always related to certain vehicle behaviour, it is important that no repairs have been made to the vehicle that may have caused the complaint. In case a repair is executed the information is no longer consistent with the Test plan and it is better to start a new diagnostic session.

7.9 Quitting Guided Diagnosis

When Guided Diagnosis is finished, it is possible to end it by selecting "Exit" from the "Go to" pop-up menu in any screen.

When exiting, a screen will appear to inform that is possible to reset the Fault codes from the units.

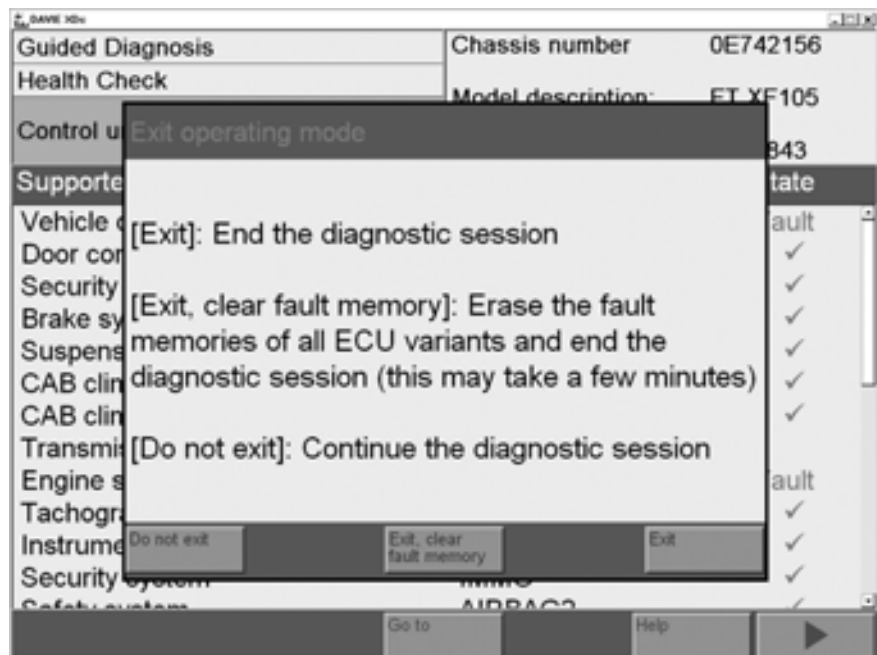

Figure 7-27 Decision: erase fault memory content

When quitting Guided Diagnosis, the following screens could appear:

- Switch contact Off/ On
- Systems needs time to refresh

NOTE

When the Fault codes are reset at the end of a diagnostic session, both pending and stored errors will no longer be available for interrogation in Guided Diagnosis or Direct Test.

8 ADMINISTRATION

8.1 Overview

Administration groups together basic set-up functions for the DAVIE XDc II. To access all Administration settings, you must login as administrator.

The following Administration functions are available for the administrator:

- "Install update":
Installation of update 1st language.
- "Change language":
Change to the second language (only if 2nd language is installed).
- "Dealership Identifier":
Input or change of DAVIE XDc II name in "Information Window".
- "Initial Graphic":
Selection of the initial picture on the startscreen.
- "Version information":
Version information about the Runtime, Application and Parts Rapido Subset
- "Contents of application data":
Information about the installed application data.
- "Passwords":
Add or change Users and Passwords.
- "Log files":
Read out the stored Log files:
- "Helpdesk log files":
Read out the stored helpdesk log files.
- "Vehicle test files":
Read out the stored Vehicle test files.
- "Service level key":
The Service level key can only be used in confer with your Local Helpdesk.

8.2 Start Administration

Administration is activated from the start screen by selecting the Administration button after login as the administrator, Master Technician and Senior Technician.

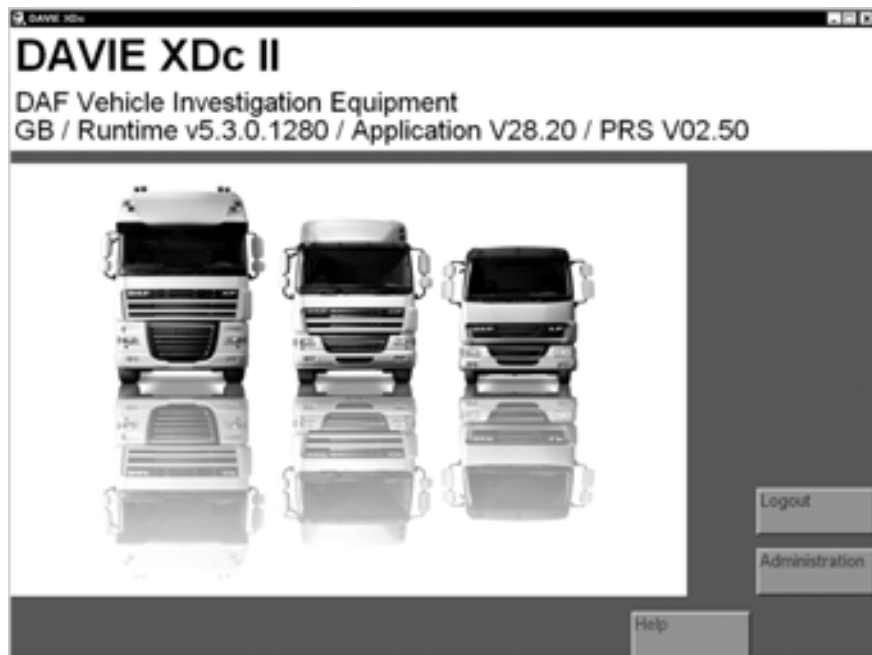

Figure 8-1 Start screen after login as the administrator

Choose this button in the start screen, the DAVIE XDc II will offer a list of accessible functions (see Figure 8-2).

	Administrator	Master Technician	Senior Technician
Install Update	X	X	X
Change language	X	X	X
Dealership Identifier	X		
Initial Graphic	X		
Version information	X		
Contents of application data	X		
Passwords	X		
Log files	X	X	X
Helpdesk Log Files	X	X	X
Vehicle test files	X	X	X
Service level key	X		

Figure 8-2 Table with administration functions per user

8.3 Select Function

Login as "Administrator" and select the "Administration" button in the start screen (see Figure 8-1), the following screen will appear. It contains a list of all accessible functions in Administration mode.

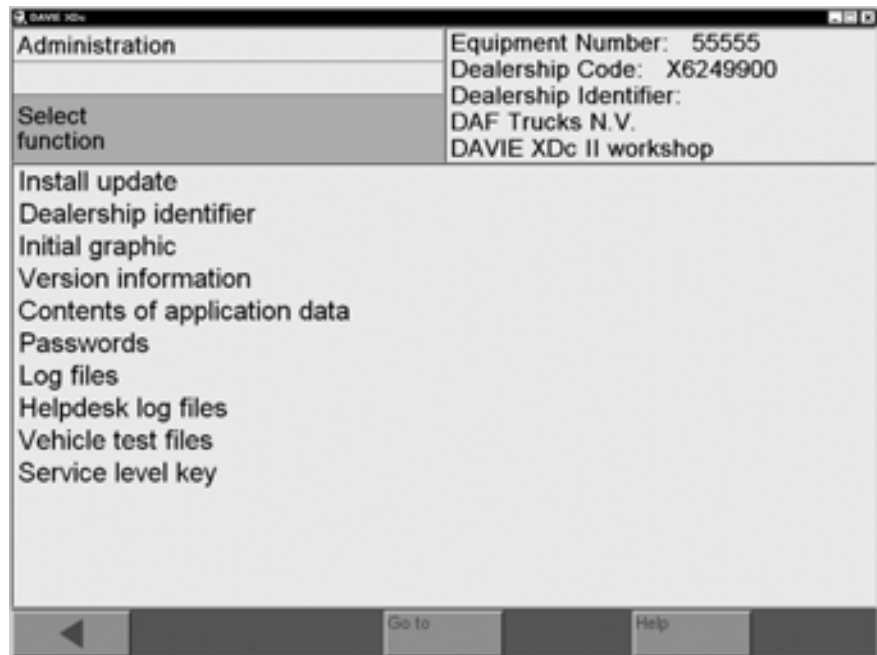

Figure 8-3 Administration screen: select function

Select any function with the selection bar. This calls up a screen in which you can edit the function.

In the top right-hand information window, the DAVIE XDc II equipment number and the dealership code are displayed automatically as soon as it has been entered. The dealership identifier is permanently displayed during Administration mode.

Using the "Back / <" button, you can return from any administration function screen to the Administration screen and from there to the system start screen.

8.4 Install update

There are two ways to update the DAVIE XDc II software.
You can install updates like the Runtime, Application and Parts Rapido Subset by new delivered CD's or you can update via the Dealernet.

8.4.1 Install update of a new Runtime CD:

For the update of the DAVIE XDc II application, a separate instruction will be send along with the Runtime update CD.

8.4.2 Install update of a new delivered Application CD:

1. Insert the CD you want to install use in the DVD drive.
2. Close the automatic started Windows XP screen that pops up.
3. Select the function "Install update".
4. You can install up to two languages. Select the language(s) and press "OK".
If only one language is selected, go to step 6.

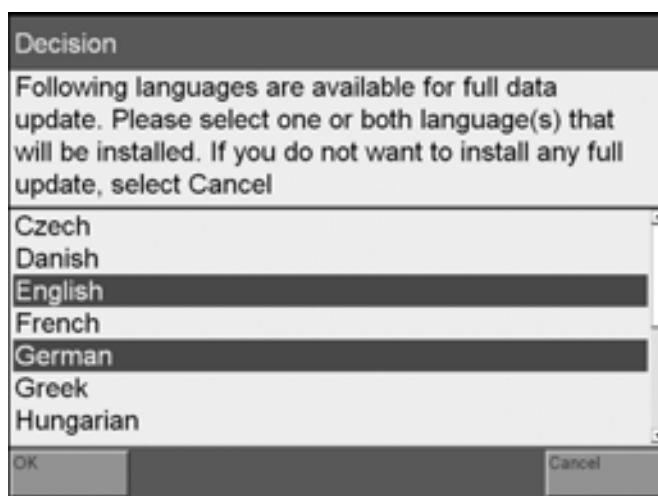

Figure 8-4 Select language of Application

NOTE

When a first language already has been installed, a second language can be added. See chapter "Install second language".

5. Select which language has to be the first language.

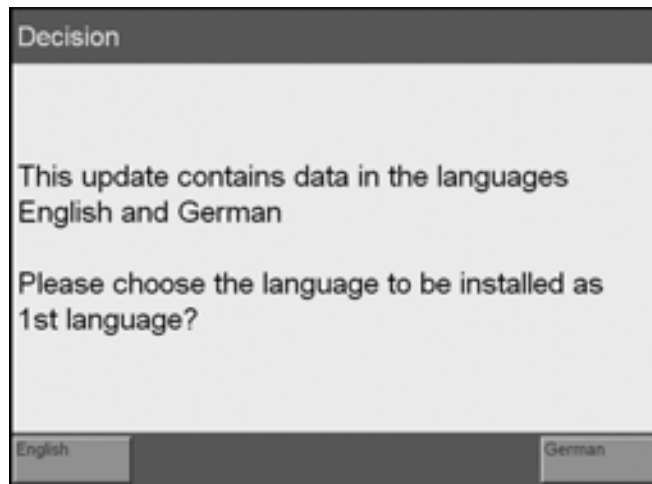

Figure 8-5 Select first language of Application

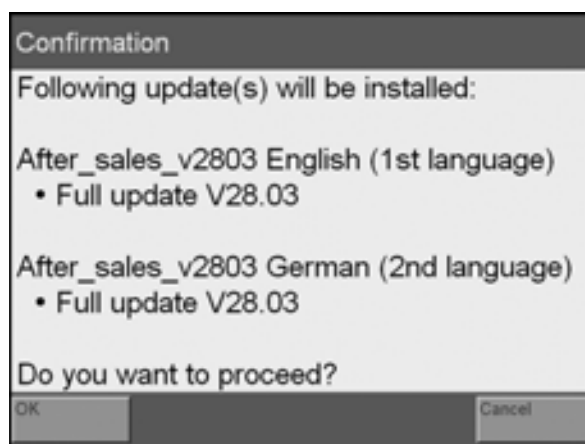

Figure 8-6 Select first language of Application

6. Press "OK" to install the selected update(s).

The application(s) will be installed on the DAVIE XDc II. A progress indicator allows you to track the installation process.

As soon as it is finished, the DAVIE XDc II jumps to the start screen.

7. Remove the CD from the drive.

NOTE

You can only load CDs that are no older than the period of validity set by DAF. CDs older than that will be rejected.

Any second language that was previously installed will be deleted during an update.

8.4.3 Install a second language

By selecting "Install update", you can also initiate the installation of a second language with the same version as the first language.

This is only necessary if a second language is to be used on the same DAVIE XDc II. In this case, only the language-specific parts of the software (knowledge bases, text files, etc.) are installed.

Up to two different languages can be installed on one DAVIE XDc as long as the software versions remain identical to each other. The first language can be overwritten with another language or the second language can be added.

Procedure to install the 2nd language

1. Insert the application CD in the DVD drive. (The same version as 1st language)
2. Close the automatic started Windows XP screen that pops up.
3. Select the function "Install update".
4. Select the desired language and press "OK".
5. Select "Add" to add the second language.

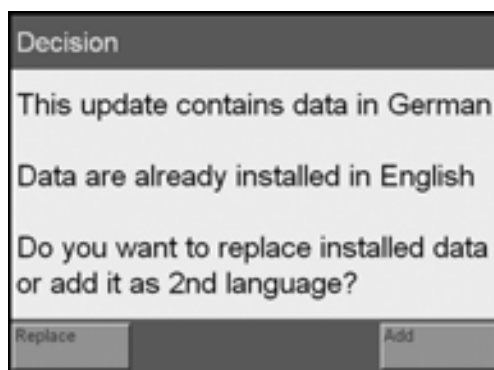

Figure 8-7 Select "Replace first language or add second language"

6. Confirm the security prompt to update or install the inserted CD.
7. The contents of the CD are installed in the Basic Unit. An on-screen progress indicator allows you to track the installation process.
8. As soon as it is finished, a message will appear indicating that the system will be restarted to complete installation process.
9. Remove the CD from the drive.
10. Confirm the message box.
11. The application will restart automatically.
12. After rebooting, the system and the application data are changed to the new second language.

8.4.4 Install update of a new Parts Rapido Subset CD

1. Insert the Parts Rapido Subset CD you want to install in the DVD drive.
2. Select the function "Install update".

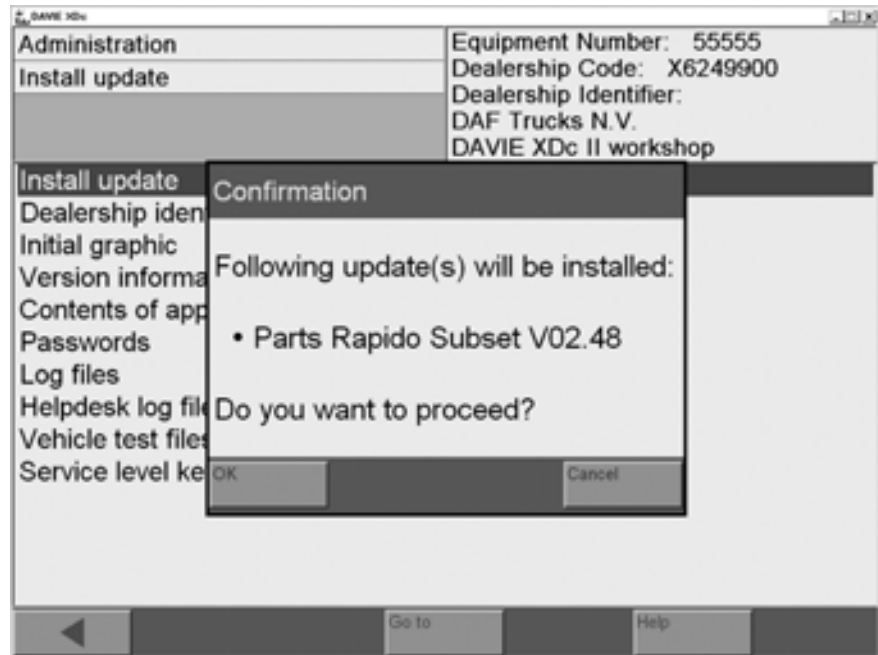

Figure 8-8 Confirm for Parts Rapido Subset installation

3. Press "OK" to install the selected update.
4. The Parts Rapido Subset will be installed on the DAVIE XDc II. A progress indicator allows you to track the installation process. As soon as it is finished, the DAVIE XDc II jumps to the start screen.

8.4.5 Install update(s) from DAVIE XDc Download.

1. Copy the files to the media (do not use a space in the folder name).
2. Insert the media you want to use in the DAVIE XDc II.
3. Select the function "Install update".
4. If the files have not been copied to the root of the media a screen pops up.
5. Navigate to the appropriate folder's label file and click OK.
6. Confirm the security prompt to install the inserted CD.
7. The update will occur.

8.4.6 Install update from Parts Rapido online

1. Copy the unzipped files to the media (do not use a space in the folder name).
2. Insert the media you want to use in the DAVIE XDc II.
3. Select the function "Install update".
4. If the files have not been copied to the root of the media a screen pops up.
5. Navigate to the appropriate folder's label file and click OK.
6. Confirm the security prompt to install the inserted CD.
7. The single chassis update will occur.

8.5 Change language

To switch between the languages, until a new application CD is installed, an additional "Change language" selection button is available in administration. It is also possible for the normal user to change the language.

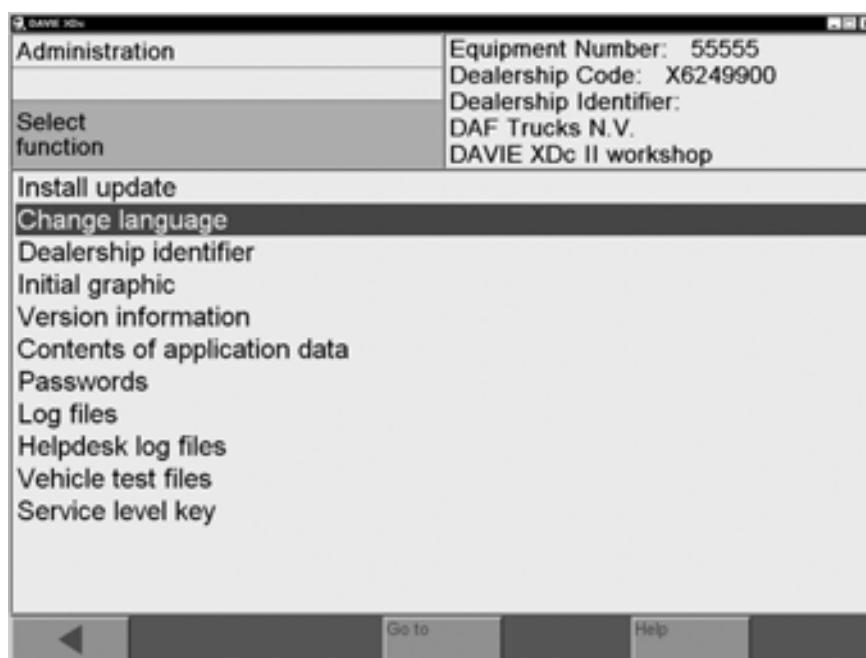

Figure 8-9 Select: Change language

NOTE

Each time you change the language, the application will be restarted.

8.6 Dealership identifier

The DAVIE XDc II could be assigned your with a dealership identifier to easily identify the DAVIE XDc II.

When the function has been selected with the selection bar, an alphanumeric keyboard appears on screen. Use the "SH" button to switch between a keyboard with upper case and special characters or with lower case characters and numbers.

Enter the data in up to two lines each using the 60 letters and digits available, spaces and any of the following special characters: , + - * / = # &.

NOTE

Language-specific special characters are not available.



Figure 8-10 Keyboard

8.7 Initial Graphic

The initial graphic is displayed graphic in the start screen.

When you select the "Initial Graphic" function in the function list, a preview of the stored "Initial Graphics" is displayed.

Use the "Forward / >" button to go step by step through all available "Initial Graphics". Use the "Back / <" button to accept the displayed graphic in the start screen.

DAVIE XDc II

Administration

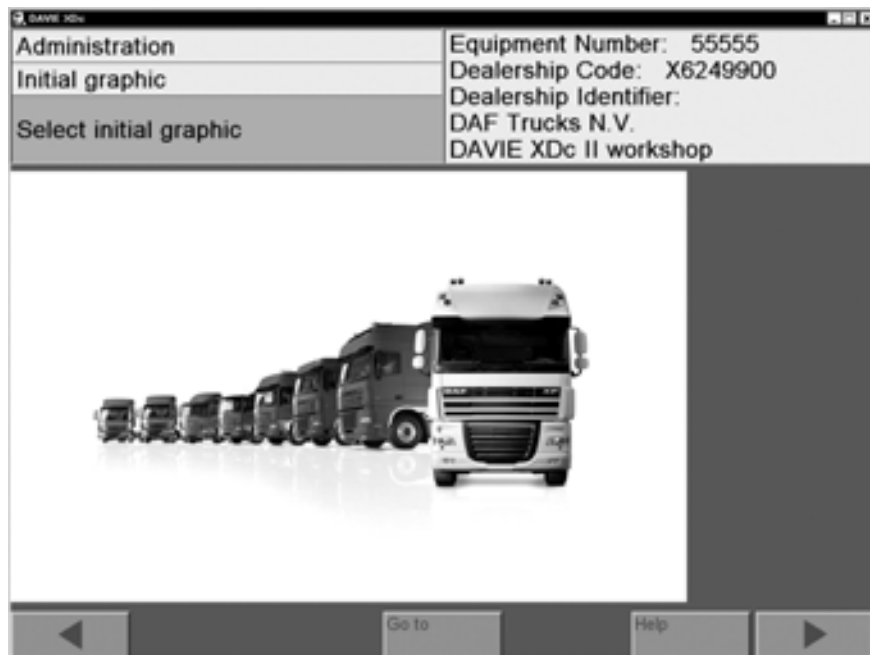

Figure 8-11 Select "Initial Graphic"

8.8 Version information

When you select the "Version information" function in the function list, the screen displays version information about the installed Runtime, Application and Parts Rapido Subset.

8.9 Contents of application data

When you select the "Contents of application data" function in the function list, the screen displays information about the application data installed on the system (information is only available in English).

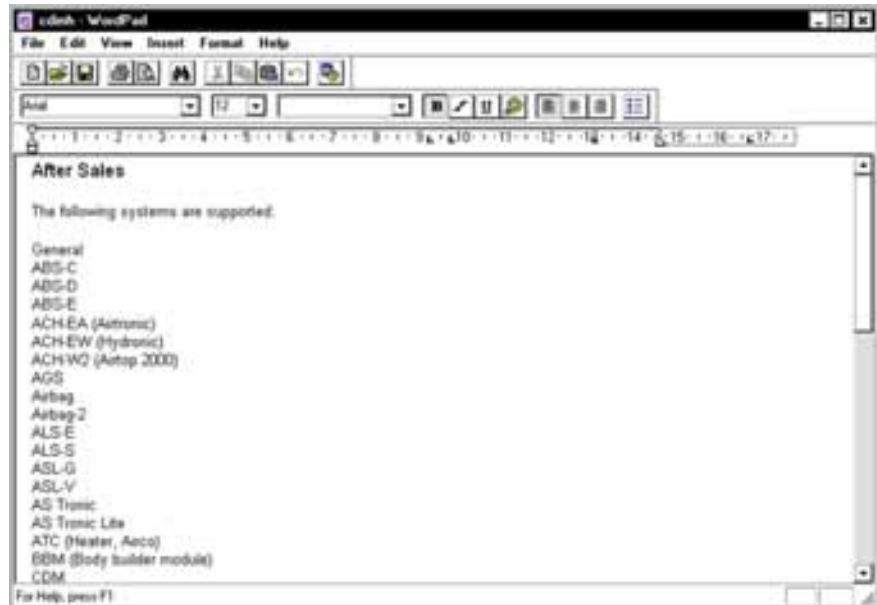

Figure 8-12 Example of the "Contents of application data"

8.10 Passwords

NOTE

This function is only available when logged in as administrator.

In the "Passwords" screen, users of the DAVIE XDc II system and passwords can be added and changed. All entered users are displayed with their hidden passwords and user levels.

- To edit an entry, select the relevant element in the "User ID" column. A dialog box opens in which you can edit the user level of the selected user.
- To add an additional user, select an empty element in the "User ID" column.
- To enter or change passwords, select the corresponding element in the "Password" column.

NOTE

Depending on the different user levels "Senior Technician" and "Master Technician" only those test procedures to which the specific technician level has access will be displayed by the DAVIE XDc II and implemented by the technician.

Only the Administrator has the right to the Password settings.
If a column is selected, a virtual keyboard appears and a new user can be added or a selected one can be changed.

8.11 Log Files

Each Diagnostic Session of the DAVIE XDc II is automatically logged into a log file on the hard disk.

You can use this function to view the saved data from "Direct Test" or "Guided Diagnose" which is stored into the log files with Adobe Acrobat.

The files can be printed out or exported to a USB-Stick or other media.
When you select the "Logfiles" function a Windows box opens and the desired "Log File" can be selected.

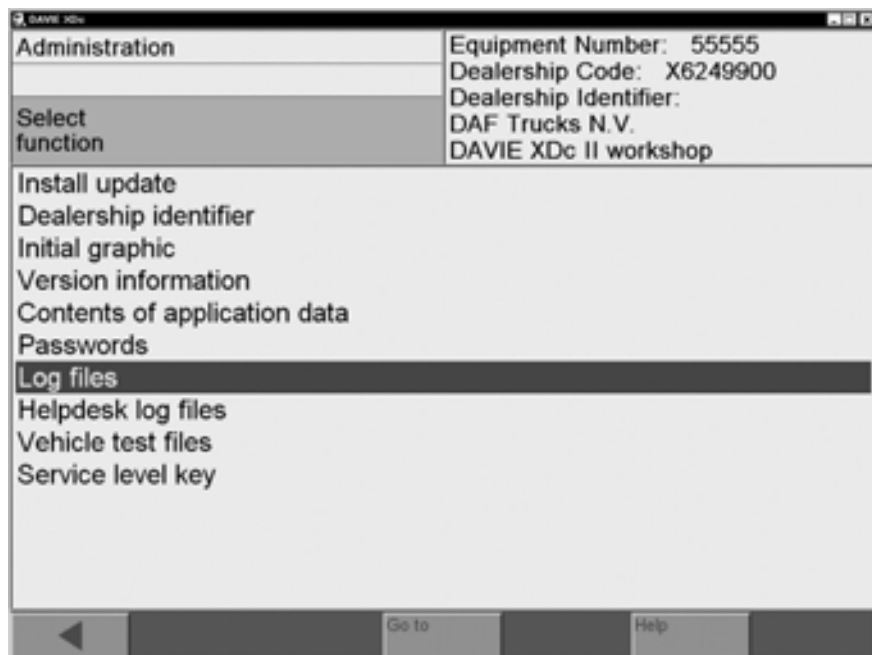

Figure 8-13 Selection of "Logfiles" in the function list

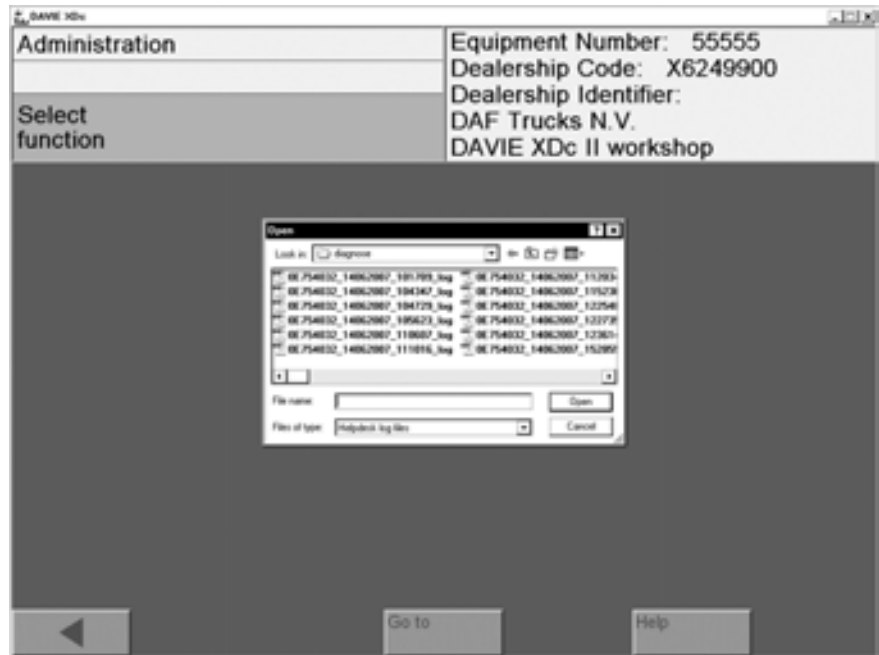

Figure 8-14 Example of the "Windows Explorer screen"



Figure 8-15 Example of the "Content of a logfile"

8.12 Helpdesk Log Files

The 'Helpdesk Log files' equal as the "Logfiles" but saved in the English language.

NOTE

These files are very valuable for the Helpdesk. If the DAVIE XDc II generates an error, please send the corresponding "Helpdesk Log Files" to the Helpdesk.

8.13 Vehicle test Files

This function works like "Log Files" but it displays "Vehicle test files". In contrast to log files, these are not automatically generated but written only when instructed to do so in the function test.

9 VCI CONFIGURATION MANAGER

VCI Configuration Manger is a software program to:

- View the status of the VCI.
- To configure the VCI according to the user's requirements.
- To display VCI specific information.
- To configure the VCI Configuration Manger according to the user's requirements.

9.1 VCI Tray Icon

The tray icon is similar to the VCI symbol on the front side of the housing and is shown in the system tray. The tray icon displays the status of the VCI connection.

The standard functionality connection status between DAVIE XDc II and VCI:

- White: Disconnected
- Blue: USB
- Green: WLAN



Figure 9-1 VCI Tray Icon

Hovering

When the mouse pointer hovers over the VCI tray icon for 1 second, the status is displayed for approx. 5 seconds:

- Connection status between DAVIE XDc II and VCI: connected or disconnected.
- Connection type: WLAN, USB or not available, if status is disconnected.
- Network name SSID, if available.

Double click left

With double click on the VCI tray icon with the left mouse button the VCI Configuration Manager will be started directly.



Figure 9-2 VCI Tray Icon double left click

Single click right

With a click on the VCI tray icon with the right mouse button a context menu is displayed with the following sections:

- About: The VCI Configuration manager software version will be displayed.
- Start VCI Configuration Manager: The VCI Configuration Manager will be started directly.
- Status Info: The same information when hovering over the tray icon.
- Exit: Close the system tray icon.



Figure 9-3 VCI Tray Icon single right click

9.2 Start up the VCI Configuration Manager Program

First close the DAVIE XDc II application before start up the VCI Configuration Manager with the shortcut in the Windows Start menu or double-click the VCI Tray Icon in the System Tray.



Figure 9-4 VCI Configuration Manager Icon

The VCI Configuration Manager provides four property screens:

- Status Info: View the software versions and communication settings
- Basic Setup: Easily configure the VCI setting
- Advanced Setup: For advanced settings (network specialists)
- Common Setup: Configuration utilities, VCI buffer settings and selftest

9.2.1 Status info

The status information screen shows specific information about the VCI.



Figure 9-5 Status info screen

DAVIE XDc II

VCI Configuration Manager

Status Info

VCI Serial Number	This shows the VCI serial number which is connected to the DAVIE XDc II. The information is only available if the VCI is connected by USB.
VCI MAC address	This is an address that is required for every port or device that connects to a network. Use these addresses to locate specific ports in the network. The information is only available if the VCI is connected by USB.
VCI Firmware Version	The version number of the VCI currently connected. The information is only available if the VCI is connected by USB.
Tester Firmware Version	This shows the version of the VCI firmware which is installed on the DAVIE XDc II.
Tester Software Bundle	This shows the version of the VCI Software which is installed on the DAVIE XDc II.
Connection Status	This shows the connection status between the DAVIE XDc II and the VCI.
Connection type	This shows the connection type of the VCI. This must be USB, WLAN or ---. The dash (---) will be displayed when the VCI is not connected.
Network name (SSID)	The Network name (SSID) for the WLAN Connection that is currently configured on the VCI.
Save Report File	Press this button to generate a report file which could be used for support from the helpdesk or to archive the current settings.
OK	The VCI Configuration Manager closes automatically. If changes are made in other screens these changes will be set.
Cancel	The VCI Configuration Manager will close without any changes

NOTE

If pressed OK, a confirmation screen is displayed.
VCI and Tester settings will be overwritten !
Be sure that "Windows automatic wireless network configuration" is enabled.
See the User manual for more information.

Normally the "Windows automatic wireless network configuration" are already been set at delivery. These settings must be done only after a complete reinstallation of Windows XP.

To check this setting, use the following instructions:

- Press with the <right touchpad key> on the Wireless Zero Configuration tray icon.
- Select <Use Windows to manage WI-Fi>
- Then click "Start", click "Control Panel", click "Network and Internet Connections", and then right click "Wireless Network connection", click "Properties" and chose "Wireless Networks".
- The checkbox must be selected.

NOTE

The firmware version may only differ from the DAVIE XDc II and VCI right after a VCI software update on the DAVIE XDc II. The firmware on the VCI will be updated when the DAVIE XDc II application is started next time. This update takes approximately one minute time.

9.2.2 Basic Setup

This screen is normally used to select a Wireless network adapter or to change the VCI-ID Network Name (SSID).

If more than one VCI is used in the same workshop, the Basic Setup can be used to easily setup a unique VCI-ID Network Name (SSID).

First connect the USB cable between the VCI and the DAVIE XDc II and connect the VCI with the Vehicle Diagnostic Cable to the vehicle before selecting the "Basic Setup" screen.



Figure 9-6 Basic Setup screen

DAVIE XDc II

VCI Configuration Manager

Basic Setup

Network Adapter	Choose the Wireless Network Adapter that has to be used to communicate with the VCI. Normally the internal Wireless Network Adapter of the DAVIE XDc II is pre selected. The internal Wireless Network Adapter is preferred.
Network Name (SSID)	The default Network Name is VCI-01. This is the default network name between the DAVIE XDc II and the VCI.
OK	The settings will be changed in the VCI and DAVIE XDc II and the Configuration Manager closes automatically.
Cancel	The VCI Configuration Manager will close without any changes

NOTE

The network name must be unique. If other VCI's or Wireless Networks nearby are using the same name, change the network name.

The Network name (SSID) will be stored in the VCI and on the local Wireless Network Adapter which was selected above.

NOTE

The configuration is automatically created and applied to the VCI and DAVIE XDc II.

The "Basic Setup" sets a WEP-key secured network connection between VCI and the DAVIE XDc II.

9.2.3 Advanced Setup

NOTE

The "Advanced Setup" only configures the VCI settings. Configuration of the DAVIE XDc II must be set using programs provided by Windows or the manufacturer of your WLAN network adapter hardware.

Therefore only use the Advanced Setup when you have knowledge about Windows XP and wireless network settings.

Only the VCI configurations are displayed and are read at the start-up of the VCI Configuration Manager.

First connect the USB cable between the VCI and the DAVIE XDc II and connect the VCI with the Vehicle Diagnostic Cable to the vehicle before selecting the "Advanced Setup" screen.

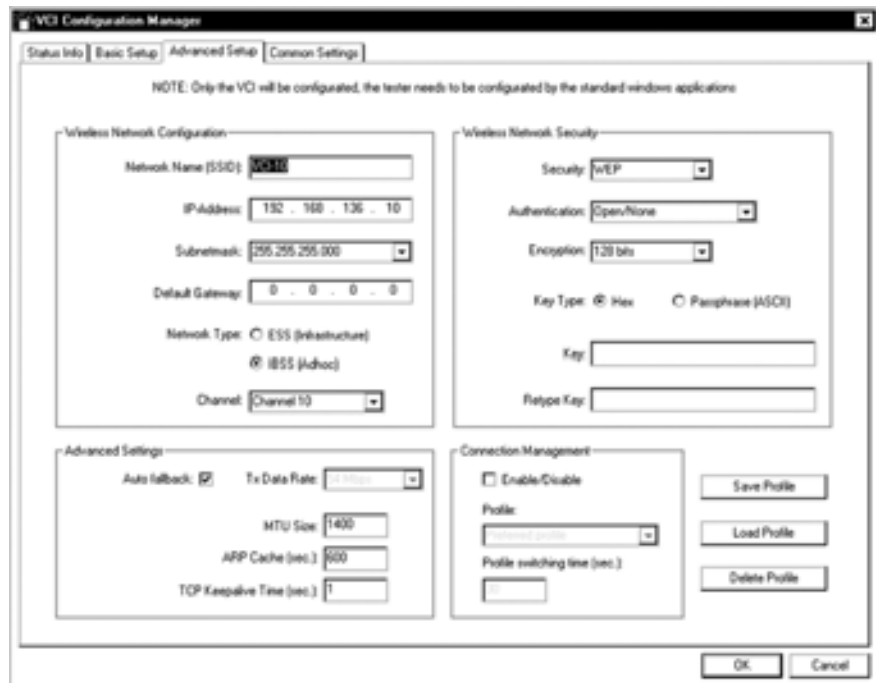

Figure 9-7 Advanced Setup screen

Wireless Network Configuration

- Network Name (SSID) Choose a Network Name (SSID) that is not used by other Wireless Networks nearby.
- IP-Address IP-Address of the VCI in the Wireless Network.
- Subnetmask Subnet Mask for the VCI used in the Wireless Network. Choose the appropriate subnet mask for your network from the listed values.
- Default Gateway Default Gateway used by VCI to connect to other networks.
- Network Type
 - Infrastructure: Connection with an Access-Point.
 - Ad-Hoc: For a direct connection between DAVIE XDc II and VCI
 - Channel RF channel IS used for wireless communication.

NOTE

Please take care. The selected RF channel has to conform to the local regulations of your country.

Wireless Network Security

Security

- None: No encryption: no security.
- WEP: Wired Equivalent Privacy: basic security
- WPA: Wi-Fi Protected Access: high security (only available in infrastructure networks).

Authentication

- WEP: Open / None: no authentication / Shared: shared key authentication (not recommended as it offers a security vulnerability).

- WPA: Pre Shared Key (PSK).

Encryption

Length of encryption key.

- WEP: 64 bit: offers only low security

- 128 bit: recommended.

- WPA: TKIP or TKIP+WEP.

Key Type

- Hex: Enter the key in hex format (for 128 bit key enter 26 characters, for 64 bit key enter 10 characters)

- Passphrase (ASCII): Passphrase (ASCII): Enter the key in ASCII format (for 128 bit key enter 13 characters, for 64 bit key enter 5 characters).

Key

Type the key which will be used for encryption of the data in the Wireless Network WPA: 8 ... 63 characters.

Retype Key

Must be the same key as above to verify that the key has not been mistyped.

Advanced Settings

Auto fallback

- Enabled: The best working data rate is used. As quality of data transmission deteriorates with distance data transmission rate (TxDataRate) is decreased to keep the connection alive.

- Disabled: The connection drops when transmission quality is not sufficient for that data rate any more.

TxDataRate

Datarate for transmission (only available if Auto fallback is not enabled). The higher the data rate the shorter is the distance for a stable connection to the VCI.

MTU Size

Maximum Transfer Unit Size: TCP Parameter, only used by Network Administrators.

ARP Cache (sec.) Address Resolution Protocol Cache expiration time: TCP Parameter, only used by Network Administrators.

TCP Keepalive Time (sec) TCP Parameter, only used by Network Administrators.

Connection Management

Enabled: Connection Management is active. Two profiles ("Preferred"/"Alternative") are supported. After power up the VCI configures itself and uses profile "Preferred". If no connection from DAVIE is established within a certain time, VCI switches its configuration to profile "Alternative". In this mode it waits an unlimited time for incoming connections.

Disabled: Connection Management is not active.

Profile

Preferred: Configure profile "Preferred".

Alternative Configure profile "Alternative".

Profile switching time (sec) Waiting time to switch to other profile if no communication is established with preferred profile.

NOTE

For the Preferred and the Alternative profile the same IP address has to be used. To restart this process the VCI has to be powered again.

Load / Save / Delete Profiles

Save Profile Save the configuration in a profile file.

Load Profile Load the configuration from a previously saved profile file.

Delete Profile Delete a previously saved profile file.

9.2.4 Common Settings

This page contains status information and controls features of the VCI and VCI Configuration manager settings which are not in context with Basic Setup:

- Language selection VCI Configuration Manager.
- Enable/disable WLAN interface.
- Setting VCI buffer time.
- Enable/disable VCI buffering.
- Selftest.

DAVIE XDc II

VCI Configuration Manager

Only the language for the user interface of the Configuration Manager can be selected independent of the connection of the VCI to the DAVIE XDc II. All other settings are only available with USB connection.



Figure 9-8 Common Settings screen

VCI WLAN

Enabled

The WLAN module of the VCI is activated. A WLAN connection can be used for communication.

Disabled

WLAN cannot be used. Only cable communication via USB is possible.

NOTE

Please take care. The use of wireless communication has to conform to the local regulations of your country.

VCI Buffering

Enabled

When the ignition is switched off, the VCI is buffered by the battery.

Disabled

No buffering when VCI is disconnected from power supply.

Buffer Time Time the built-in battery buffers VCI during the vehicle ignition is switched off.

The buffer time for ignition status handling can be chosen between 20 and 60 seconds in steps of one second. The default setting is 20 seconds.

Recommended: Enable and 20 seconds

Language Selection

Choose the language you want to use for the VCI Configuration Manager user interface.

Dutch	US English	Danish	Czech
French	Italian	Finnish	Hungarian
German	Spanish	Norwegian	Russian
British English	Greek	Polish	Turkish

***Default:** US English*

After a restart of the VCI Configuration Manager the language is changed.

Self Test

- Press the button "Start Selftest" to check your VCI hardware.
- Tests that pass are marked with a green checkmark. If a test fails a red checkmark is displayed

NOTE

If the Selftest detect a Wireless error, please run the "Basic Setup".

10 HELP

10.1 Overview

In the "Help" mode, you can access context-sensitive or general operating hints and explanations of functions. "Help" does not replace the user manual but it can help you if you are uncertain how to use screens or buttons so that you do not have to refer to the user manual.

The help function is divided into two groups:

- Topics
- Buttons

10.2 Start Help

The "Help" button appears on every screen on the DAVIE XDc II. It is always in the same place on the navigation bar. Press it if you need more information about a screen or a button.

The DAVIE XDc II remains in "Help" mode as long as the "Help" button remains dark.

You cannot change any settings or selections in this mode.

Exit "Help" mode by pressing the "Help" button again.

Help is open - the button is active

Help is closed - the button is not active



Figure 10-1 Help active / Help not active

10.3 Help Overview

The "Help overview" dialog box appears when you start "Help" mode. It contains a list of one or more topics for which a brief explanation is available. A selection bar highlights the current topic.

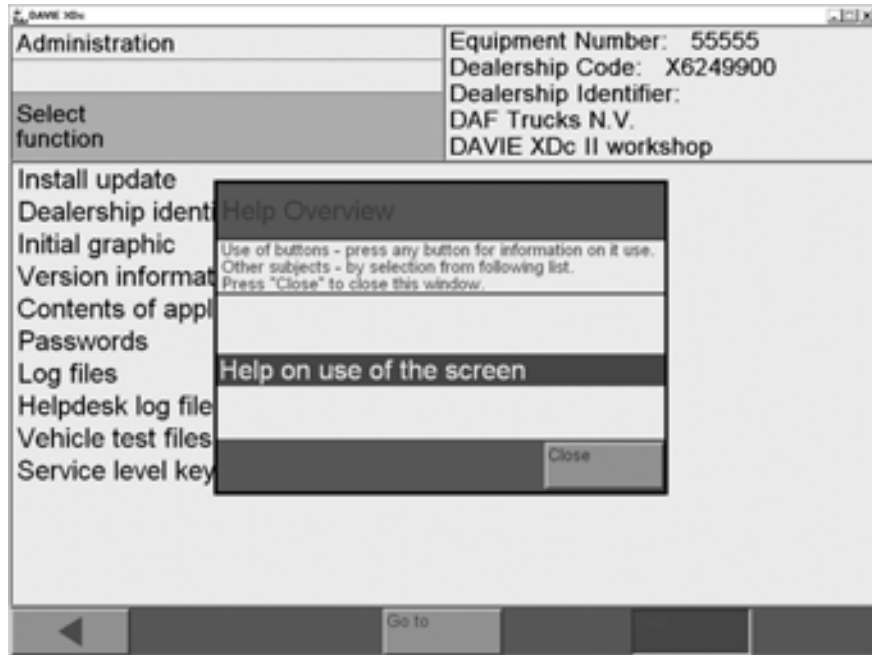

Figure 10-2 Help overview in the screen

The "Close" button closes the "Help overview" so that you can see the buttons that may be hidden behind it. However, the tester remains in "Help" mode.

10.4 Help on Topics

The help text will be displayed when you open a topic. This explains the options you have in the current screen. There you can see what you can do in the screen and the links to other screens.

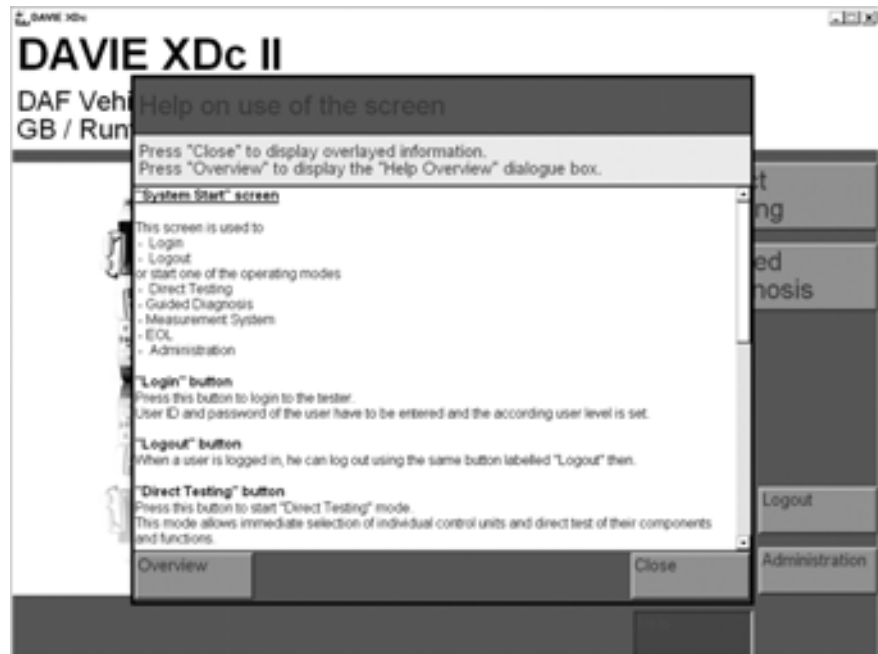

Figure 10-3 Help on use of the screen

Screen explanation:

- The scroll bar on the right side of the dialog box can be used to scroll the text up or down so that you can read the whole text.
- The "Overview" button returns you to the "Help overview".
- The "Close" button closes the Help dialog box so that you can see the other buttons that may be hidden behind it. However, the tester remains in "Help" mode.

10.5 Help on the selected button

You can get help for any button in any screen.

Press any button while the DAVIE XDc II is in "Help" mode and a brief explanation of the button's meaning and use will appear on the screen. Close the "Help overview" window if you need to see the buttons behind it.

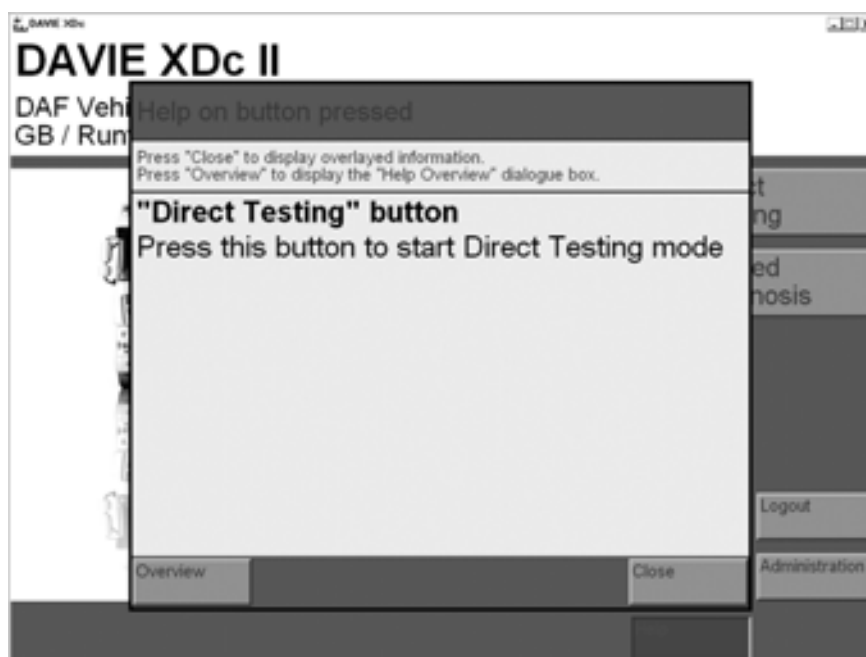

Figure 10-4 Help on the "Direct Testing" button

- The "Overview " button returns you to the "Help overview ".
- The "Close" button closes the "Help on button pressed" dialog box so that you can see the buttons behind it. However, the tester remains in "Help" mode.

NOTE

No help is available for the "Overview" and "Help" buttons.

11 TROUBLESHOOTING

The DAVIE XDc II was completely installed and tested before being shipped.

Selected components and compliance with specified quality controls guarantee that the DAVIE XDc II will be extremely dependable. However, if a problem should occur, consult the notes in this chapter before you contact the local Helpdesk.

11.1 Classification

Any problems that the DAVIE XDc II may have can be classified into the following groups:

- Problems related to ambient influences: ambient temperature, (extreme) humidity, dust, soot, grease, sparking, power supply, transformers, large electric motors, two-way radio equipment and vibration.
- Problems in the DAVIE XDc II: Laptop, Vehicle Communication Interface, battery and/or Cables
- Problems related to the wireless communication: Network settings, installed Drivers.

Try to identify the problem and localize it if possible. Try the suggested solutions and carry out all the measures listed.

If the problem cannot be solved, please contact the local Helpdesk.

11.2 Computer Hardware

11.2.1 Laptop self test

The laptop checks itself each time it is powered up. If error messages appear after this self-test, refer to the original delivered laptop documentation. If the problem can not be solved, contact the Local helpdesk.

Before contacting the Helpdesk, please have the following information ready:

1. Laptop type and Serial No.
2. VCI type and Serial No.
3. Used or installed Runtime version (e.g. V5.3.0)
4. Used or installed Application data (e.g. V29.02)
5. Used or installed Parts Rapido Subset (e.g. V02.52)
6. If a failure message appears, make a screenshot or write down the text or numbers of the message.

11.2.2 Laptop does not work correctly

Laptop does not work correctly

Solution:

To solve this problem, use the original documentation which is delivered with the laptop.

WARNING

If the power cable or DAVIE XDc II is damaged, you must not use the cable until a qualified specialist has tested and, if necessary, repaired the equipment.

WARNING

The power cable must not be laid over tables, benches or cabinets. They must not be located near hot objects or rotating parts.

WARNING

The length of the power cable must not be extended. Use only the supplied power cable as far as possible.

WARNING

DAVIE XDc II is a safety class 1 device and is equipped with a safety tested power cable. It may only be connected to systems with equipment grounding conductors (TN systems) and grounding sockets.

WARNING

To reduce the risk of electric shock, do not use on wet surfaces or expose to rain.

11.2.3 Touchscreen (optional)

There are problems in using the touchscreen, the position where your fingertip presses the screen and the cursor position is different.

Solution:

To solve this problem, use the original documentation which is delivered with the laptop.

11.3 Software installation

11.3.1 Windows Explorer popup

After selecting the function "Install update", first the DAVIE XDc II checks if the label-file is present on an expected location on the CD and removable media. A Windows Explorer pops up if the file can not be found.



Figure 11-1 Windows popup

Possible causes for these problems are:

- No CD in DVD drive
- Not a DAVIE XDc II Application data CD
- Not a Parts Rapido Subset CD

Solution:

Place CD in DVD drive

CD is damaged.

Solution:

Insert an undamaged DAVIE XDc II CD into the DVD drive and try again.

DVD drive not initialized.

Solution:

Check if the drive is inserted correctly.

Files are not copied to the location on the Floppy, CD-R or USB-stick where DAVIE XDc II expects them.

Solutions:

Navigate to the appropriate folder's label file and click OK.

11.3.2 CD incompatible with Base-CD

After confirming to update, the DAVIE XDc II compares the compatibility version of the Application and Parts Rapido Subset CD with the Runtime version. If the compatibility does not match the following screen will be displayed.

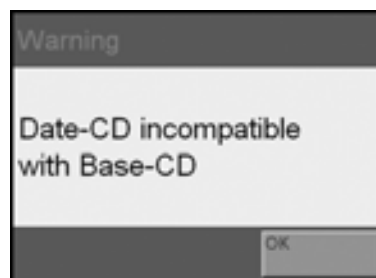

Figure 11-2 Data CD incompatible with Base-CD

Possible causes for these problems are:

Wrong Application or Parts Rapido Subset update.

Runtime is out of date.

Solution:

Check the latest version information on the Dealernet and install the latest software if available.

If the DAVIE XDc II is up to date, contact the local helpdesk.

11.3.3 Problems with application data

Problem:

If, after starting "Direct Testing" or "Guided Diagnosis", the system tries to load up application data, but cannot find the right version or any data, the following message box will be displayed:

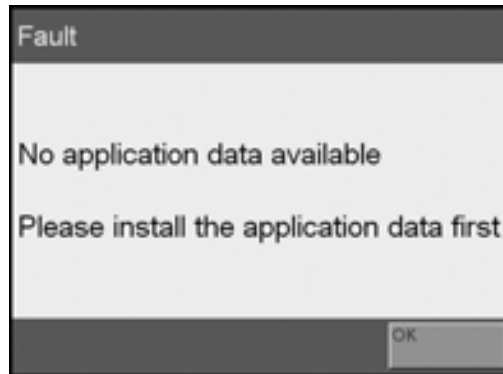

Figure 11-3 Error Message Application Data

Solution:

- Install latest DAVIE XDc II Application and Parts Rapido Subset CD
- If the problem still exists, contact the local helpdesk and send a "Helpdesk Log File"

11.4 Problems with Vehicle Communication Interface (VCI)

11.4.1 Self-test of the VCI Configuration Manager.

For service purposes a "Selftest" is provided to get information about potential defects of the hardware. The "Selftest" generates a result which will be displayed as a "check" item or a "failed" item.

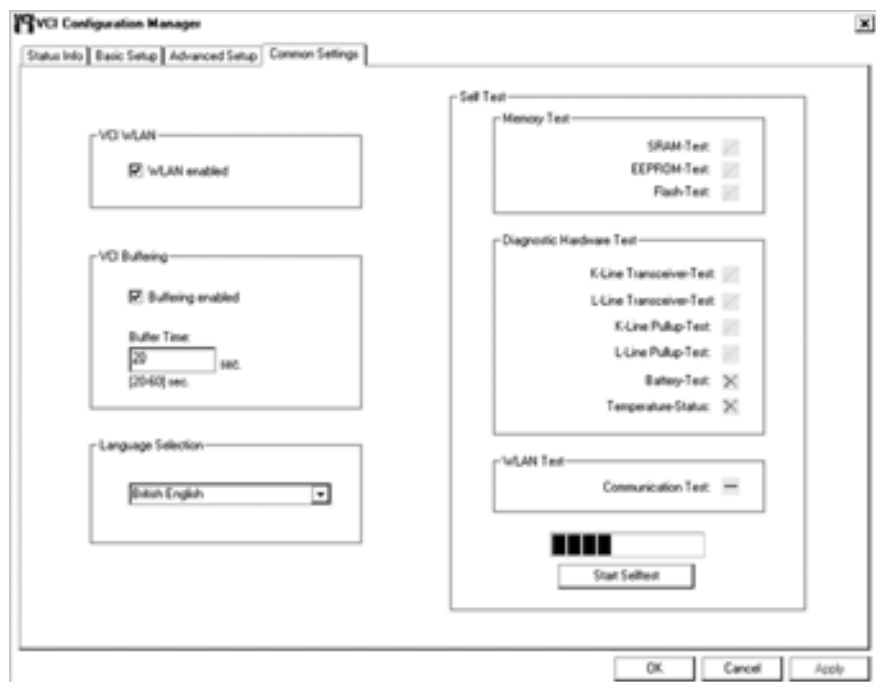

Figure 11-4 Error Message Application Data

DAVIE XDc II

Troubleshooting

Detailed information is available in the report file. This will be generated after a "Selftest" sequence.

The "Selftest" procedure is separated into two parts.

1. The VCI hardware will be tested.
2. The wireless communication between DAVIE XDc II and VCI will be checked.

NOTE

For the wireless communication test, the USB connection has to be removed and a working WLAN-profile on the DAVIE XDc II and the matching settings on VCI are assumed. Refer to chapter "VCI Configuration manager".

Before using the "VCI Configuration Manager" to carry out the self-test for the Vehicle Communication Interface, close the DAVIE XDc II program.

If there is a WLAN error, please refer the error list. For detailed instructions how to carry out the self-test, refer to Chapter "Configuration Manager".

Before contacting the local Helpdesk, please have the following information ready:

1. Laptop type and Serial No.
2. VCI type and Serial No.
3. Used or installed Runtime version (e.g. V5.3.0)
4. Used or installed Application data (e.g. V29.02)
5. Used or installed Parts Rapido Subset (e.g. V02.52)
6. If a failure message appears, make a screenshot or write down the text or numbers of the message.
7. Report file of the VCI configuration manager.

11.4.2 VCI Configuration Manager Self-test error list

Test Item	Value	Meaning	Action
SRAM	00	OK	No action needed
	01	Not OK	Contact the local helpdesk
EEPROM	00	OK	No action needed
	01	Not OK	Contact the local helpdesk

Test Item	Value	Meaning	Action
FLASH	00	OK	No action needed
	01	Not OK	Contact the local helpdesk
K-Line Transceiver	00	OK	No action needed
	01	Not OK	Contact the local helpdesk
L-Line Transceiver	00	OK	No action needed
	01	Not OK	Contact the local helpdesk
K-Line Pullup	00	OK	No action needed
	01	Not OK	Contact the local helpdesk
L-Line Pullup	00	OK	No action needed
	01	Not OK	Contact the local helpdesk
Battery	00	OK	No action needed
	01	Not present	Insert battery if available.
	02	Defective	Contact the local helpdesk
	04	Sensor of battery defective	Contact the local helpdesk
	06	Battery and temperature sensor defective	Contact the local helpdesk
Temperature Status	bit coded values (more than one bit could be set)		
	00	Sensors OK	No action needed
	01	Sensor 1 defective	Contact the local helpdesk
	02	Sensor 2 defective	Contact the local helpdesk
	04	Sensor of accu defective	Contact the local helpdesk
	08	Sensor of accu not present	Contact the local helpdesk

11.4.3 Wireless Communication recovery

The DAVIE XDc II communicates with the ECU's installed in the truck via the truck side "Diagnostic Connector" by using a special communication interface, called the Vehicle Communication Interface (VCI). The VCI switches the input channel automatically to the required data line (K-line, L-line) or CAN-bus of the truck side "Diagnostic Connector".

The DAVIE XDc II provides two options for the communication between VCI and DAVIE XDc II, radio and USB communication.

The safest way to change the communication is to close the DAVIE XDc II program and connect or disconnect the USB-cable.

If an error message about the WLAN appears after this self-test, carry out the following actions

1. Connect the USB cable between the VCI and the DAVIE XDc II.
2. Connect the VCI with the Vehicle Diagnostic Cable to the vehicle.
3. Open the "VCI Configuration Manager" by the shortcut in the Windows Start menu or double-click the VCI Tray Icon in the System Tray (See also chapter "VCI Configuration Manager").
4. The unique network name (SSID) is displayed in the "Status Info" screen.
5. Go to the "Basis Setup" screen.
6. Change the "Network Name (SSID) to a desired unique name which is not used nearby. For Example: VCI-02. Only use alpha numeric symbols. For example 1, 2, ect. and a, b, c, ect. Do not use: ! @ # \$ % ^ & * ().
7. Press "OK" to apply the setting. The settings will be changed in the VCI and DAVIE XDc II.
8. VCI Configuration Manager is closed automatically.
9. Open the "VCI Configuration Manager" and select the "Common Settings" screen.
10. Press "Selftest" and follow the instructions on the screen.
11. If still an error message about the WLAN appears, refer the error list.

If the problem can not be solved, contact the Local helpdesk

Before contacting the Helpdesk, please have the following information ready:

1. Laptop type and Serial No.
2. VCI type and Serial No.
3. Used or installed Runtime version (e.g. V5.3.0).
4. Used or installed Application data (e.g. V29.02).
5. Used or installed Parts Rapido Subset (e.g. V02.52).
6. If a failure message appears, create a "report file" in the "VCI configuration Manager".
7. Report file of the VCI configuration manager.

11.5 Fault Report to Local helpdesk

If you cannot fix or resolve the problem, please contact the Helpdesk by phone or by e-mail.

Describe the fault characteristics (message, etc.) as precisely as possible, when it occurred and what you were doing when it occurred, what you have done to localize the problem, the results of your actions and the following basic information:

1. Laptop type and Serial No.
2. VCI type and Serial No.
3. Used or installed Runtime version (e.g. V5.3.0)
4. Used or installed Application data (e.g. V29.02)
5. Used or installed Parts Rapido Subset (e.g. V02.52)
6. If a failure message appears, make a screenshot or write down the text or numbers of the message.
7. The "Helpdesk Log file" and/or a "report file" in the "VCI configuration Manager".

12 CARE AND MAINTENANCE

12.1 Visual check of the DAVIE XDc II components

Regularly carry out a visual check of all DAVIE XDc II components. Check all parts for damage (e.g. cracks, etc.) and dirt contamination.



CAUTION

Regularly check all cables for damage.

Always replace damaged cables.

12.2 Cleaning the components

12.2.1 Cleaning the laptop



CAUTION

Before cleaning the DAVIE XDc II Laptop refer to the originally delivered laptop documentation.



CAUTION

Before cleaning the DAVIE XDc II Laptop switch it off and unplug the power supply cable.

12.2.2 Cleaning the VCI



CAUTION

Before cleaning the VCI switch it off and unplug the Vehicle Diagnostic Cable. To clean the housing of the VCI use a cleaning cloth with light washing-up liquid, washing gasoline or alcohol.

Don't use aggressive cleaning liquids.

12.3 Batteries

12.3.1 Laptop battery

See the original documentation which is delivered with the laptop.

12.3.2 VCI battery



CAUTION

- Danger of explosion with inappropriate replacement or treatment of the battery.
 - Never open the battery.
 - Replace the battery only against the original spare part of the manufacturer.
 - Dispose used batteries according to the local regulations and terms.
 - Do not throw batteries in open fire and keep the batteries away from heat sources with temperatures above 65°C.
 - Do not throw the batteries into water.
 - Do not short circuit the battery.
 - Storage cool and dry.
-

The estimated battery lifespan is approx. 2 years, depending on the storage and operating conditions, e.g. temperature.
New batteries need to be refreshed after 3 month storage.

A bad or old battery is indicated by the battery status indicator.
The red battery LED is permanent on if a battery malfunction is detected.

12.3.3 Replace the VCI battery

The VCI battery is plugged direct into a connector fixed at the bottom of the battery compartment. The VCI battery is normally maintenance-free and will be charged each time the VCI is connected to the vehicle.

If it is necessary to replace the VCI battery because the battery is faulty, then follow the procedure below:

1. Disconnect the VCI from the vehicle and DAVIE XDc II.
2. Remove the battery plug by turning the plug counter clockwise with a big screwdriver.
3. To remove the battery, turn the VCI around and clap the complete VCI with the open battery tray against your palm. Now the battery will unplug itself and you can remove it easily.
4. Put the new battery with the green connector first into the battery compartment. The plug will slide in the compartment by an easy push.

5. Install the battery plug. The battery enclosure cap must be screwed tightly. This can be best realised by using a big screw driver.

Disposal procedure:

- Faulty and worn out batteries must be disposed in accordance with the currently applicable national regulations.
- In EC countries, defective batteries must be recycled or disposed according to regulation 91/157/EC.
- Do not dispose used batteries with household waste or throw into fire or water.
- Do not open batteries.

DAVIE XDc II

Care and Maintenance
